

TMC550 55" Wall-mountable Touchscreen Monitor



Product Brief

Vantron 55-inch wall-mountable touchscreen monitor delivers optimal visual effects and seamless touch experience. It is perfect for applications such as digital signage, product branding, electronic menus, and conference collaboration. Its durable design and reliable performance make it suitable for continuous use in high-traffic environments. When paired with Vantron OPS players, it can easily transform into a full-function all-in-one panel PC.

TMC550 makes touches smoother and more responsive by leveraging the industry-leading PCAP technology that allows for multi-touch with latex or cotton gloves. The screen is designed to resist fingerprints, and users have the option to equip the touch screen with anti-glare and anti-reflection coatings for improved visual experience and more accurate human-machine interaction. The VESA pattern on the device allows it to be perfectly embedded in checkouts or fully enclosed self-service terminals or to be flexibly mounted on any proper surfaces in the desired direction.

Exterior and Features

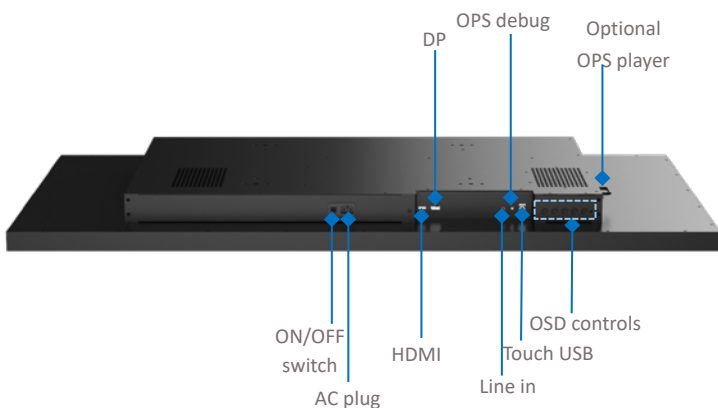

TMC550	
	Full HD display with vast applications
	PCAP technology, enabling multi-touch with gloves
	AF finishing, AR/AG touch screen available
	OPS player compatible to offer an all-in-one solution
	Flexible installation with VESA patterns
	Excellent longevity (50,000H MTBF)
	Three-year warranty

55" Wall-mountable Touchscreen Monitor Datasheet

TMC550		
Display	Diagonal size	55" TFT LCD with LED backlight
	Aspect ratio	16:9
	Resolution	3840 x 2160 @60Hz
	Brightness	500 nits
	Active area	1210.6mm × 681.4mm
	Contrast ratio	1200:1
	Number of colors	1.07B
	Response time	8ms
	Viewing angle	89/89/89/89 (U/D/L/R)
Touch panel	Touch point	10-point PCAP touch screen
	Touch control	Finger, stylus pen, touch with gloves
	Cover lens	IK03 rated (Optional: IK07)
	Surface treatment	Anti-fingerprint, tempered glass (Optional: Anti-glare / Anti-reflection)
	Light transmittance ratio	>85%
	Touch communication interface	USB 2.0 Type-B
Video	Video interface	1 x DP 1.2 1 x HDMI 1.4
Audio	Audio interface	1 x Line in (3.5mm jack) 2 x 5W speaker (Optional)
Mechanical	Dimensions	1280mm x 750mm x 87.5mm
	Weight	39kg
	Installation	VESA mount (400mm x 400mm)
	Display rotation	OSD lockout / OSD rotation
System Control	OSD	Keys: Menu, Up, Down, Back, Power Options: brightness, contrast, language, color temp., video interface...
	Indicator	1 x RGB indicator (Red: standby; Green: working)
	Button	1 x ON/OFF switch
Software	Power input	100 ~ 240V AC 50/60Hz
	Power consumption	Typical: 110W (without OPS player)
	Language	Chinese and English
Environment Condition	Temperature	Operating: 0°C~+40°C Storage: -20°C~+60°C
	Humidity	0%~95% RH (non-condensing)
	MTBF	50,000 hours
	Warranty	3 years
	ESD	ESD: ±4KV (contact) and ±8KV (air)
	Certificate	CCC, FCC, CE

Product Outlines

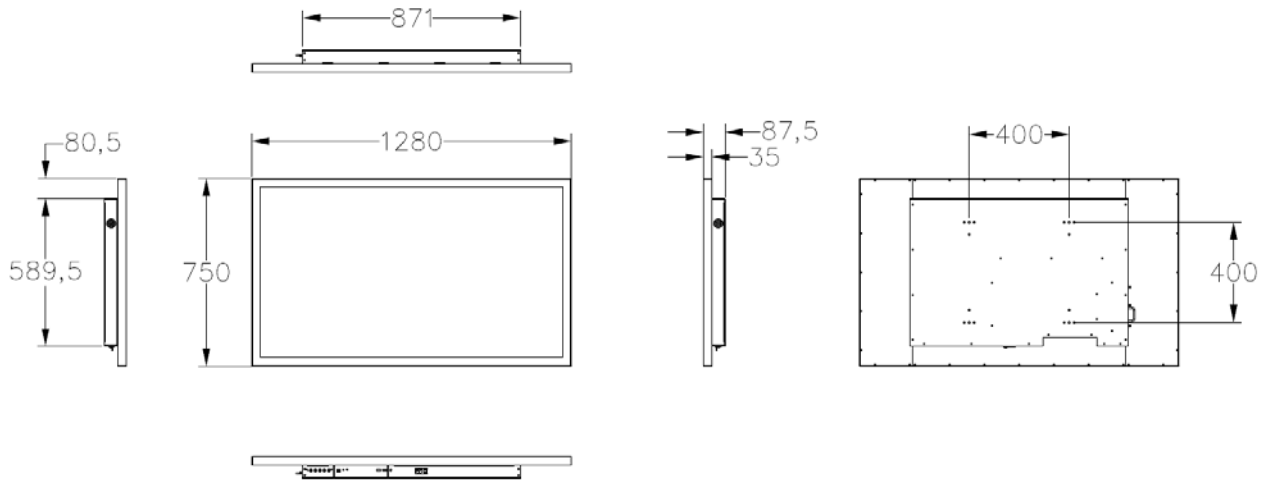

Ordering Information

Ordering No.	AG	AR
TMC550-G	Yes	-
TMC550-GR	Yes	Yes
TMC550	-	-

Optional accessories	
DP cable	1

Packing List	
TMC550 touchscreen monitor	1
Power cable	1
Touch USB cable	1
HDMI cable	1
Qualified certificate	1

Since its establishment in 2002 by two Silicon Valley entrepreneurs, Vantron Technology has been at the forefront of the connected IoT devices and IoT platform solutions. Today, Vantron boasts a global customer base that includes several Fortune 500 companies. Its product lines cover edge intelligent hardware, IoT communication devices, industrial displays and BlueSphere cloud device management platform.

Vantron’s intelligent display systems are comprised of mobile PCs, touchscreen monitors and all-in-one panel PCs that deliver enhanced device performance and exceptional human-machine interactive experiences. The mobile PCs are powered by industry-leading brands such as Rockchip, NXP, MediaTek, and Intel. The touchscreen monitors offer flexible installation options to cater to various application scenarios. The all-in-one panel PCs offer an overall solution that integrates the touchscreen monitor, display, processor, and operating system. Moreover, the displays are built to excel in harsh environments thanks to advanced features like waterproofing, dustproofing, and shatter resistance.

TMC550 V1.5 © 2023 Vantron Technology, Inc. All rights reserved. Vantron Technology, Inc. reserves the right to update or modify this document at any time without prior notice.