

Table of Contents

1.	Overview	1
1.1	Product Brief	1
1.2	Features	1
1.3	Block Diagram	2
1.4	Product Outlines	2
1.5	Applications	2
1.6	Specifications	3
1.7	Pinout.....	4
2.	System Design	10
2.1	Power Management	10
2.2	Interfaces	10
2.3	Recommended Usage Schematics	11
3.	Electrical Characteristics	12
3.1	Absolute Maximum Ratings	12
3.2	Recommended Operating Conditions.....	12
3.3	Power Consumption	13
3.4	RF Specifications	14
4.	Ordering Information.....	16
5.	Company Profile.....	16

VT-SOM-AH Wi-Fi HaLow Module



1. Overview

1.1 Product Brief

VT-SOM-AH offers a complete Wi-Fi HaLow connectivity solution that incorporates the Morse Micro MM6108 single-chip SoC, which is in compliant with IEEE 802.11ah standard, and an ARM Cortex-M33 ultra-low-power MCU that offers a variety of functions including I²C, UART, USB, CAN, ADC, and GPIO. This smart module is designed to be readily integrated into any embedded device to provide a simplified Wi-Fi HaLow connection solution for customers looking to easily upgrade their prior RF technology to a Wi-Fi HaLow connection while using the latest WPA3 security protocol.

VT-SOM-AH offers an SPI slave interface. It operates between 850MHz and 950MHz bands and supports 1, 2, 4, and 8MHz channel widths to provide extended transmission range and faster data rate. Its MAC supports the station (STA) role and is ideally used in connecting low-power NFC tags or sensors for access control or other scenarios.

With support for multiple network protocol stacks and a range of I/O options, VT-SOM-AH speeds up the development of customized Wi-Fi HaLow solutions for IoT applications, especially in smart home appliances, industrial IoT devices, smart retail devices, gym instruments, etc.

1.2 Features

- Single-stream data rate up to 32.5 Mbps @8MHz or 15 Mbps @4MHz channel bandwidth
- Support worldwide Sub-1 GHz frequency bands
Frequency range: 850MHz~950 MHz
Channel bandwidth options: 1/2/4/8 MHz
Support 1 MHz and 2 MHz duplicate modes
- Packet detection & channel equalization
- BPSK & QPSK, 16-QAM & 64-QAM Modulation
- Modulation and Coding Scheme (MCS) levels: MCS 0~7 and MCS 10
- ARM Cortex-M33 MCU & Morse Micro MM6108 SoC
- Packaging: LGA
- RTOS system, complete Wi-Fi HaLow solution
- Compact size, self-contained functions
- Easy integration to any embedded device
- I²C, UART, GPIO for flexible expansion
- Ultra-low-power, reduced cost & time-to-market

1.3 Block Diagram

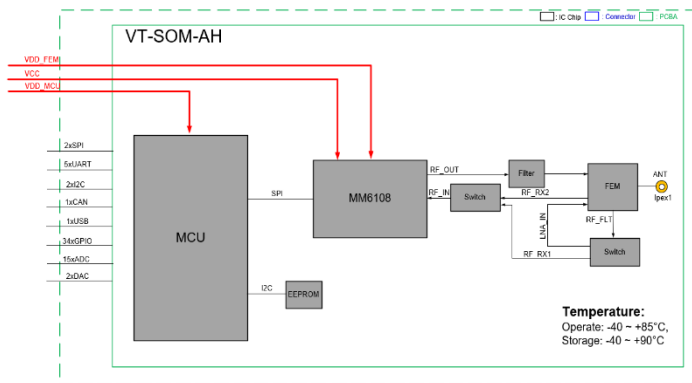

1.4 Product Outlines

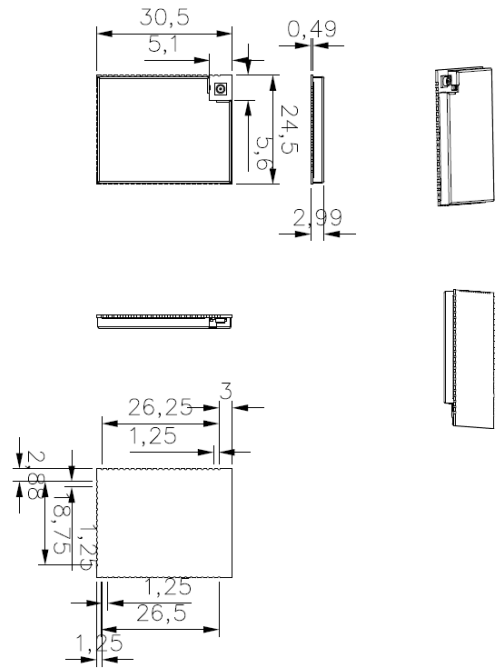

1.5 Applications

- Home automation
 - Alarm system, security cameras, smart doorbells
 - Entertainment (media streaming adapters, speakers)
 - Baby monitors
 - Garage door openers
 - Door locks
 - Smart appliances
 - Energy management
 - Voice control frontends
 - Consumer robotics
- Portables & Wearables
 - Smart watches
 - Smart glasses
 - Kids trackers
- Building automation
 - Building access control & security
 - HVAC & air quality control
 - Smart city network
 - Commercial robotics
 - EV battery charger telemetry
 - Vehicle firmware OTA update
- Retail & Logistics
 - Digital signage
 - Kiosks / POS / vending
 - Fleet management
 - Inventory management / scanners
- Industrial Automation
 - Autonomous mobile robotics
 - Material handlers / trackers

1.6 Specifications

VT-SOM-AH					
System	SoC	Morse Micro MM6108			
	MCU	STM32U, 784KB SRAM, 2MB Flash			
I/O	Pin signals*	2 x I ² C			
		2 x SPI			
		5 x UART			
		1 x USB			
		1 x CAN			
		15 x ADC			
		2 x DAC			
		34 x GPIO			
		JTAG supported			
Antenna	1 x HaLow U.FL antenna connector				
WLAN Features	Wi-Fi standard	IEEE 802.11ah			
	Frequency range (Sub 1 GHz bands)	850MHz ~ 950MHz			
	Channel bandwidth	1 / 2 / 4 / 8 MHz			
	Data rate	1 MHz	2 MHz	4 MHz	8 MHz
		3.33Mbps (Max.)	7.22Mbps (Max.)	15Mbps (Max.)	32.5Mbps (Max.)
	Security	AES encryption engine SHA1 and SHA2 hash functions (SHA-256, SHA-384, SHA-512) WPA3 including protected management frames (PMF)			
Mechanical	Dimensions	30.5mm x 24.5mm x 2.99mm			
	Voltage	VCC: 3.3V	VDD_FEM: 3.3V	VCC_WIFI: 3.3V	
	Temperature	Operating: -40°C ~ +85°C		Storage: -40°C ~ +90°C	
	Humidity	Less than 85% RH (non-condensing)			
Compliance	Certification	FCC, IC, CE			

* Pin signals indicate the maximum number of each signal the module can offer, including those with alternative uses.

1.7 Pinout

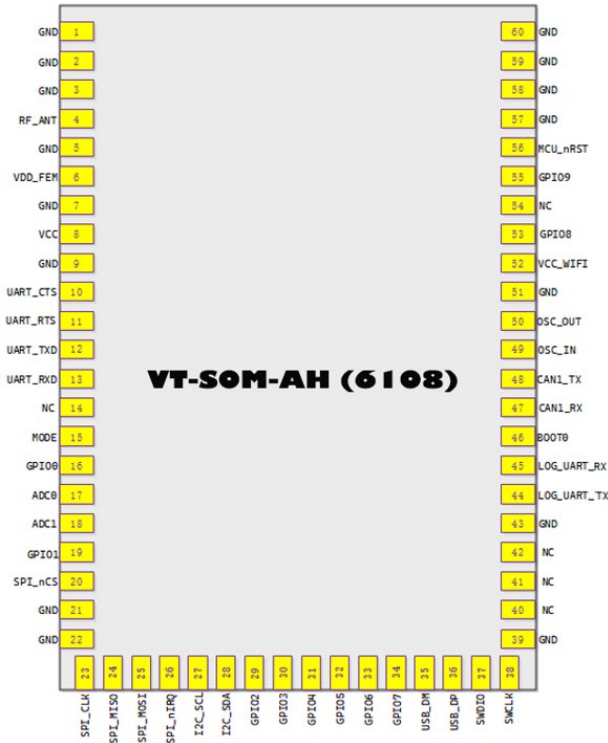

Pin	Name	Type	Description	Alternate functions	Additional functions
1	GND_1	Power	Ground	Ground	
2	GND_2	Power	Ground	Ground	
3	GND_3	Power	Ground	Ground	
4	ANT	Analog	No connection	No connection	
5	GND_4	Power	Ground	Ground	
6	VDD_FEM	Power	3.3V frontend module supply	3.3V frontend module supply	
7	GND_5	Power	Ground	Ground	
8	VCC	Power	3.3V MCU supply	3.3V MCU supply	
9	GND_6	Power	Ground	Ground	
10	UART_CTS	I	UART clear to send	TIM2_CH1, TIM5_CH1, TIM8_ETR, SPI3_RDY, UART4_TX, OCTOSPIM_P2_NCS, SDMMC2_CMD, AUDIOCLK, TIM2_ETR, EVENTOUT	OPAMP1_VINP, ADC1_IN5, WKUP1, TAMP_IN2/TAMP_OUT1
11	UART_RTS	O	UART request to send	LPTIM1_CH2, TIM2_CH2, TIM5_CH2, I2C1_SMBA, SPI1_SCK, UART4_RX, OCTOSPIM_P1_DQS, LPGPIO1_P0, TIM15_CH1N, EVENTOUT	OPAMP1_VINM, ADC1_IN6, WKUP3, TAMP_IN5/TAMP_OUT4

Pin	Name	Type	Description	Alternate functions	Additional functions
12	UART_TXD	O	UART transmit data	TIM2_CH3, TIM5_CH3, SPI1_RDY, USART2_TX (boot), LPUART1_TX, OCTOSPIM_P1_NCS, UCPD1_FRSTX1, TIM15_CH1, EVENTOUT	COMP1_INP3, ADC1_IN7, WKUP4/LSCO
13	UART_RXD	I	UART receive data	TIM2_CH4, TIM5_CH4, SAI1_CK1, USART2_RX (boot), LPUART1_RX, OCTOSPIM_P1_CLK, LPGPIO1_P1, SAI1_MCLK_A, TIM15_CH2, EVENTOUT	OPAMP1_VOUT, ADC1_IN8, WKUP5
14	NC		No connection		
15	Mode	I	Reserved for wake up from low-power mode	USART3_TX, OCTOSPIM_P1_IO7, EVENTOUT	COMP1_INM2, ADC1_IN13, ADC4_IN22
16	GPIO_0	I/O	General purpose IO	TIM1_CH4N, SAI1_D3, PSSI_D15, USART3_RX, EVENTOUT	COMP1_INP1, ADC1_IN14, ADC4_IN23, WKUP5, TAMP_IN4/TAMP_OUT5
17	ADC0	I	Analog to digital converter in	TIM1_CH2N, TIM3_CH3, TIM8_CH2N, LPTIM3_CH1, SPI1_NSS, USART3_CK, OCTOSPIM_P1_IO1, LPGPIO1_P9, COMP1_OUT, AUDIOCLK, EVENTOUT	OPAMP2_VOUT, ADC1_IN15, ADC4_IN18
18	ADC1	I	Analog to digital converter in	TIM1_CH3N, TIM3_CH4, TIM8_CH3N, LPTIM3_CH2, MDF1_SDI0, USART3_RTS_DE, LPUART1_RTS_DE, OCTOSPIM_P1_IO0, LPGPIO1_P3, LPTIM2_IN1, EVENTOUT	COMP1_INM1, ADC1_IN16, ADC4_IN19, WKUP4
19	GPIO_1	I/O	General purpose IO	LPTIM1_CH1, TIM8_CH4N, I2C3_SMBA, SPI1_RDY, MDF1_CKIO, OCTOSPIM_P1_DQS, UCPD1_FRSTX1, EVENTOUT	COMP1_INP2, ADC1_IN17, WKUP1, RTC_OUT2
20	SPI_nCS	O	SPI chip select	TIM1_BKIN, I2C2_SMBA, SPI2_NSS (boot), MDF1_SDI1, USART3_CK, LPUART1_RTS_DE, TSC_G1_IO1, OCTOSPIM_P1_NCLK, SAI2_FS_A, TIM15_BKIN, EVENTOUT	
21	GND_7	Power	Ground		
22	GND_8	Power	Ground		

Pin	Name	Type	Description	Alternate functions	Additional functions
23	SPI_CLK	O	SPI clock output	TIM1_CH1N, LPTIM3_IN1, I2C2_SCL, SPI2_SCK (boot), MDF1_CK11, USART3_CTS, LPUART1_CTS, TSC_G1_IO2, SAI2_SCK_A, TIM15_CH1N, EVENTOUT	
24	SPI_MISO	I	SPI master in slave out	TIM1_CH2N, LPTIM3_ETR, TIM8_CH2N, I2C2_SDA, SPI2_MISO (boot), MDF1_SDI2, USART3_RTS_DE, TSC_G1_IO3, SDMMC2_D0, SAI2_MCLK_A, TIM15_CH1, EVENTOUT	UCPD1_DBCC2
25	SPI_MOSI	O	SPI master out slave in	RTC_REFIN, TIM1_CH3N, LPTIM2_IN2, TIM8_CH3N, SPI2_MOSI (boot), MDF1_CK12, FMC_NBL1, SDMMC2_D1, SAI2_SD_A, TIM15_CH2, EVENTOUT	UCPD1_CC2, WKUP7
26	SPI_nIRQ	I	SPI interrupt	CSLEEP, TIM3_CH1, TIM8_CH1, MDF1_CK13, SDMMC1_D0DIR, TSC_G4_IO1, DCM1_D0/PSSI_D0, SDMMC2_D6, SDMMC1_D6, SAI2_MCLK_A, EVENTOUT	
27	I2C_SCL	O	I2C serial input clock	CDSTOP, TIM3_CH2, TIM8_CH2, MDF1_SDI3, SDMMC1_D123DIR, TSC_G4_IO2, DCM1_D1/PSSI_D1, SDMMC2_D7, SDMMC1_D7, SAI2_MCLK_B, LPTIM2_CH2, EVENTOUT	
28	I2C_SDA	I/O	I2C data input/output	SRDSTOP, TIM3_CH3, TIM8_CH3, TSC_G4_IO3, DCM1_D2/PSSI_D2, SDMMC1_D0, LPTIM3_CH1, EVENTOUT	
29	GPIO_2	I/O	General purpose IO	MCO, TIM1_CH1, SAI1_CK2, SPI1_RDY, USART1_CK, OTG_FS_SOF, TRACECLK, SAI1_SCK_A, LPTIM2_CH1, EVENTOUT	
30	GPIO_3	I/O	General purpose IO	TIM1_CH2, SPI2_SCK, DCM1_D0/PSSI_D0, USART1_TX (boot), SAI1_FS_A, TIM15_BKIN, EVENTOUT	OTG_FS_VBUS
31	GPIO_4	I/O	General purpose IO	TRACED1, LPTIM3_ETR, ADF1_CCK1, SPI3_SCK, USART3_TX (boot), UART4_TX, TSC_G3_IO2, DCM1_D8/PSSI_D8, LPGPIO1_P8, SDMMC1_D2, SAI2_SCK_B, EVENTOUT	

Pin	Name	Type	Description	Alternate functions	Additional functions
32	GPIO_5	I/O	General purpose IO	TRACED3, SPI3_MOSI, USART3_CK, UART5_TX, TSC_G3_IO4, DCMI_D9/PSSI_D9, LPGPIO1_P10, SDMMC1_CK, SAI2_SD_B, EVENTOUT	
33	GPIO_6	I/O	General purpose IO	TRACED2, TIM3_ETR, USART3_RTS_DE, UART5_RX, TSC_SYNC, DCMI_D11/PSSI_D11, LPGPIO1_P7, SDMMC1_CMD, LPTIM4_ETR, EVENTOUT	
34	GPIO_7	I/O	General purpose IO	CRS_SYNC, TIM1_CH3, LPTIM2_IN2, SAI1_D1, DCMI_D1/PSSI_D1, USART1_RX (boot), OTG_FS_ID, SAI1_SD_A, TIM17_BKIN, EVENTOUT	
35	USB_DM	I/O	USB port differential data plus	TIM1_CH4, TIM1_BKIN2, SPI1_MISO, USART1_CTS, FDCAN1_RX, OTG_FS_DM (boot), EVENTOUT	
36	USB_DP	I/O	USB port differential data minus	TIM1_ETR, SPI1_MOSI, OCTOSPIM_P2_NCS, USART1_RTS_DE, FDCAN1_TX, OTG_FS_DP (boot), EVENTOUT	
37	SWD_IO	IO	SWD data	JTMS/SWDIO, IR_OUT, OTG_FS_NOE, SAI1_SD_B, EVENTOUT	
38	SWD_CLK	O	SWD clock	JTCK/SWCLK, LPTIM1_CH1, I2C1_SMBA, I2C4_SMBA, OTG_FS_SOF, SAI1_FS_B, EVENTOUT	
39	GND_9	Power	Ground		
40	NC			JTDI, TIM2_CH1, TIM2_ETR, USART2_RX, SPI1_NSS, SPI3_NSS, USART3_RTS_DE, UART4_RTS_DE, SAI2_FS_B, EVENTOUT	UCPD1_CC1
41	NC			JTDO/TRACESWO, TIM2_CH2, LPTIM1_CH1, ADF1_CCK0, I2C1_SDA, SPI1_SCK, SPI3_SCK, USART1_RTS_DE, CRS_SYNC, LPGPIO1_P11, SDMMC2_D2, SAI1_SCK_B, EVENTOUT	COMP2_INM2

Pin	Name	Type	Description	Alternate functions	Additional functions
42	NC			NJTRST, LPTIM1_CH2, TIM3_CH1, ADF1_SDI0, I2C3_SDA, SPI1_MISO, SPI3_MISO, USART1_CTS, UART5_RTS_DE, TSC_G2_IO1, DCM1_D12/PSSI_D12, LPGPIO1_P12, SDMMC2_D3, SAI1_MCLK_B, TIM17_BKIN, EVENTOUT	COMP2_INP1
43	GND_10	Power	Ground		
44	Log_UART_TX	O	Debug UART transmit data	LPTIM1_ETR, TIM4_CH1, TIM8_BKIN2, I2C1_SCL (boot), I2C4_SCL, MDF1_SDI5, USART1_TX, TSC_G2_IO3, DCM1_D5/PSSI_D5, SAI1_FS_B, TIM16_CH1N, EVENTOUT	COMP2_INP2, WKUP3
45	Log_UART_RX	I	Debug UART receive data	LPTIM1_IN2, TIM4_CH2, TIM8_BKIN, I2C1_SDA (boot), I2C4_SDA, MDF1_CK15, USART1_RX, UART4_CTS, TSC_G2_IO4, DCM1_VSYNC/PSSI_RDY, FMC_NL, TIM17_CH1N, EVENTOUT	COMP2_INM1, PVD_IN, WKUP4
46	BOOT0	I	MCU boot	EVENTOUT	
47	CAN1_RX	I	CAN 1 receive data	TIM4_CH3, SAI1_CK1, I2C1_SCL, MDF1_CCK0, SPI3_RDY, SDMMC1_CKIN, FDCAN1_RX (boot), DCM1_D6/PSSI_D6, SDMMC2_D4, SDMMC1_D4, SAI1_MCLK_A, TIM16_CH1, EVENTOUT	WKUP5
48	CAN1_TX	O	CAN 1 transmit data	IR_OUT, TIM4_CH4, SAI1_D2, I2C1_SDA, SPI2_NSS, SDMMC1_CD1R, FDCAN1_TX (boot), DCM1_D7/PSSI_D7, SDMMC2_D5, SDMMC1_D5, SAI1_FS_A, TIM17_CH1, EVENTOUT	
49	OSC_IN	NC	High-speed external clock crystal in	EVENTOUT	OSC_IN
50	OSC_OUT	NC	High-speed external clock crystal out	EVENTOUT	OSC_OUT

Pin	Name	Type	Description	Alternate functions	Additional functions
51	GND_11	Power	Ground		
52	VCC_WIFI	Power	3.3V WIFI supply		
53	GPIO_8	I/O	General purpose IO	LPTIM3_IN1, ADF1_SDIO, DCMI_D2/PSSI_D2, OCTOSPIM_P1_NCS, SPI3_MISO, USART3_RX (boot), UART4_RX, TSC_G3_IO3, DCMI_D4/PSSI_D4, UCPD1_FRSTX2, SDMMC1_D3, SAI2_MCLK_B, EVENTOUT	
54	NC		No connection		
55	GPIO_9	I/O	General purpose IO	EVENTOUT	WKUP2, RTC_TS/RTC_OUT1, TAMP_IN1/TAMP_OUT2
56	MCU_nRST	I	MCU reset		
57	GND_12	Power	Ground		
58	GND_13	Power	Ground		
59	GND_14	Power	Ground		
60	GND_15	Power	Ground		

2. System Design

2.1 Power Management

VT-SOM-AH does not have a power jack, and it is powered by 3.0V ~ 3.6V supply derived from an external power source via pins VDD_FEM, VCC, and VCC_WIFI.

Please refer to 2.3 Recommended Usage Schematics for the connection of the power pins.

2.2 Interfaces

VT-SOM-AH offers multiple interfaces for connecting peripherals/host devices to give full play to its functions. User can use UART1 to connect the module to a host computer to debug the module.

Please refer to 2.3 Recommended Usage Schematics for the connection of CAN/UART/I²C.

■ SPI Bus Timing

The SPI interface supports a clock rate up to 50MHz.

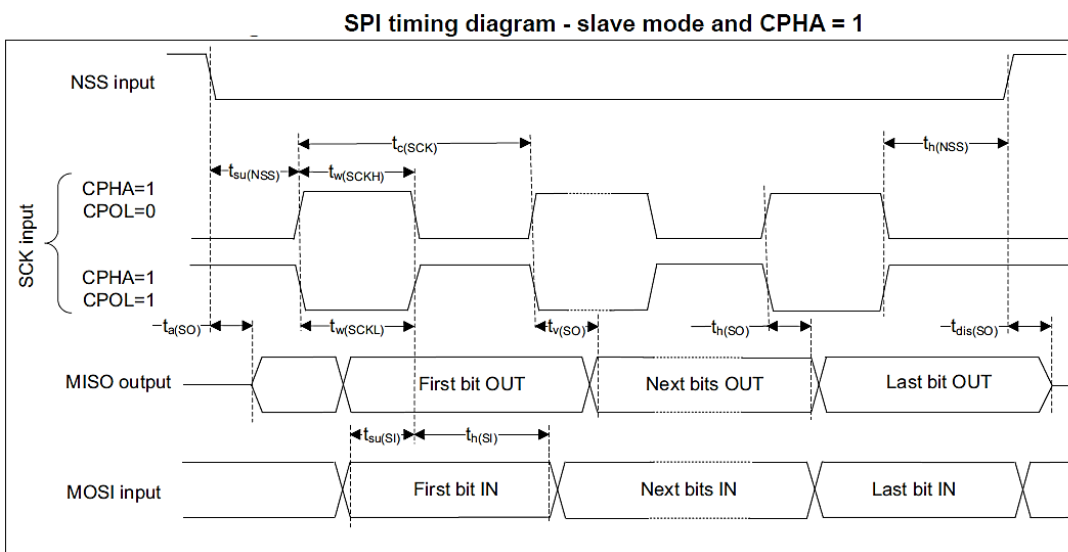
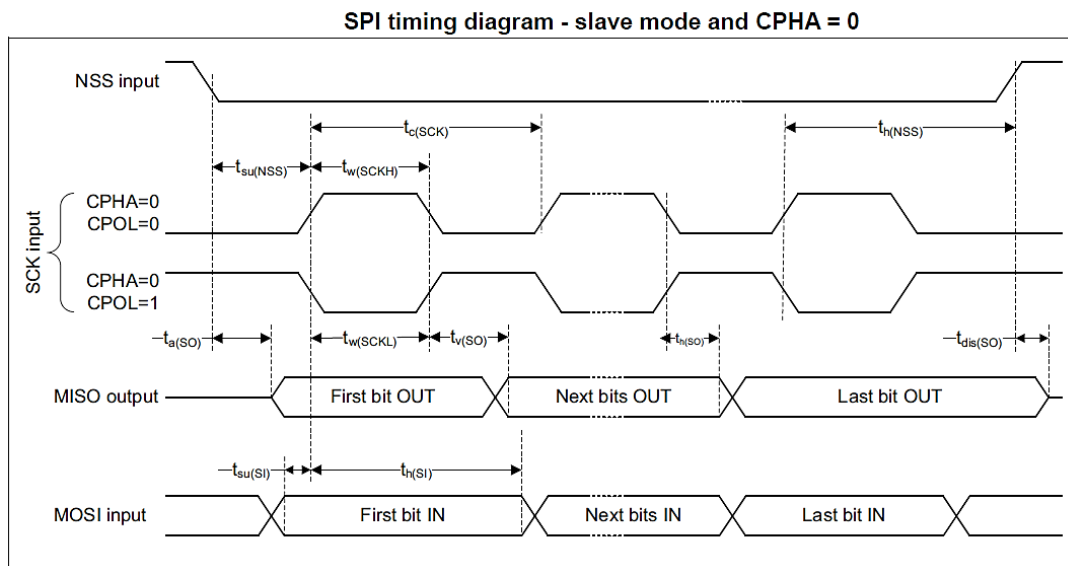

2.3 Recommended Usage Schematics

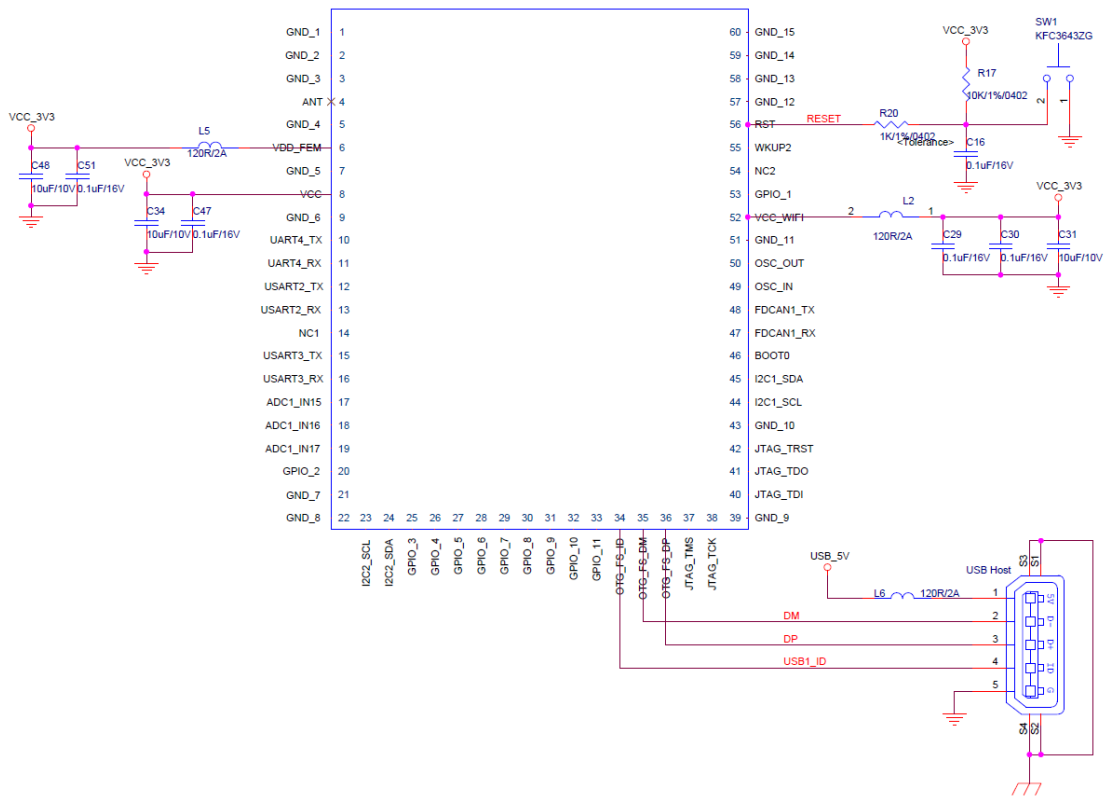

Power, Reset & USB

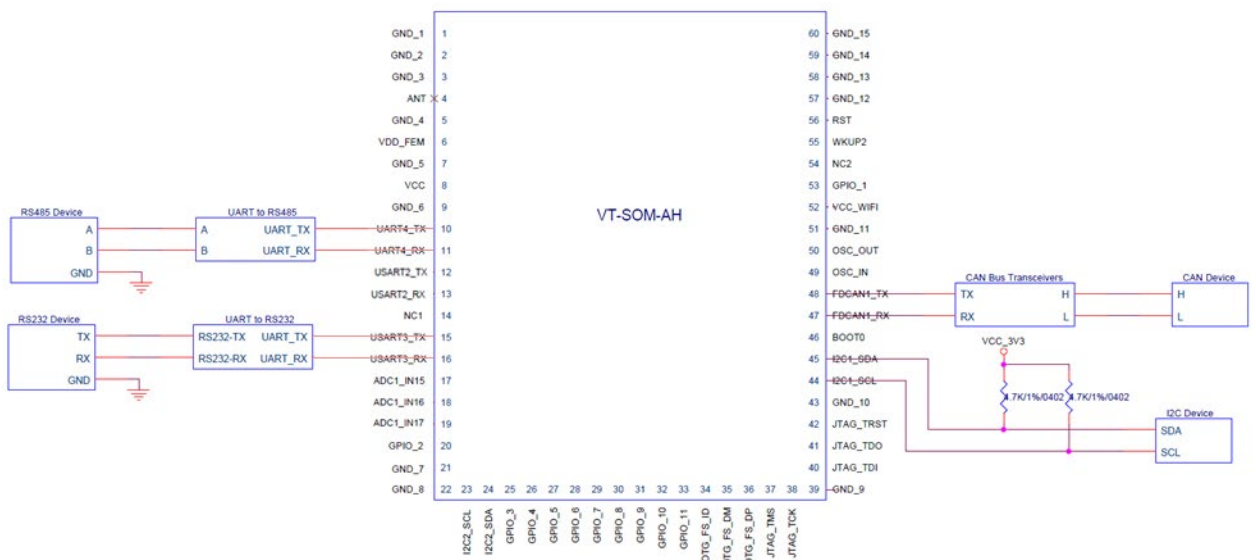

Interfaces

3. Electrical Characteristics

3.1 Absolute Maximum Ratings

Stress beyond absolute maximum ratings may cause permanent damage to the module. Functional operation is guaranteed for recommended operation conditions only. Operation of the device outside of recommended conditions may result in reduced lifetime and/or reliability problems even if the absolute maximum ratings are not exceeded.

Parameter	Min.	Typ.	Max.	Unit
VDD_FEM voltage	-0.3	3.3	4.3	V
Voltage on WIFI	-0.3	3.3	4.3	V
Voltage on MCU	-0.3	3.3	4.0	V
Storage temperature	-40	25	125	°C

3.2 Recommended Operating Conditions

Parameter	Min.	Typ.	Max.	Unit
Ambient temperature	-40	25	85	°C
VCC voltage	3.0	3.3	3.6	V
VDD_FEM voltage	3.0	3.3	3.6	V
VCC_WIFI voltage	3.0	3.3	3.6	V
Voltage on digital I/O pin	0	3.3	VCC	V
RESET / WAKE I/O Voltage	0	3.3	VCC	V

3.3 Power Consumption

Transmit power consumption

Mode	Condition	VBAT Current			VDD_FEM Current			Unit
		Min.	Typ.	Max.	Min.	Typ.	Max.	
Transmit current (MCS0, 21dBm, 100% D.C.)	1 MHz channel bandwidth	254	257	273	151	152	163	mA
	2 MHz channel bandwidth	254.5	260	273	150.5	152	159.5	mA
	4 MHz channel bandwidth	260.5	266	279.5	146.5	151	156	mA
	8 MHz channel bandwidth	271	278	291.5	142.5	147	153	mA
Transmit current (MCS7, 17dBm, 100% D.C.)	1 MHz channel bandwidth	248	251	262.5	98.5	104	112	mA
	2 MHz channel bandwidth	251.5	255	266.5	97.5	104	112	mA
	4 MHz channel bandwidth	257	262	273	93.5	102	108.5	mA
	8 MHz channel bandwidth	268	272	284	91	99	105.5	mA

Receive power consumption

Mode	Condition	VBAT Current			VDD_FEM Current			Unit			
		Min.	Typ.	Max.	Min.	Typ.	Max.				
Listen	1 MHz channel bandwidth	225	226	235.5	4	4.5	4.7	mA			
	2 MHz channel bandwidth	226	228	235				mA			
	4 MHz channel bandwidth	230	232	240				mA			
	8 MHz channel bandwidth	235	237	245.5				mA			
Active receive MCS7	1 MHz channel bandwidth	226.5	226	235.5				4	4.5	4.7	mA
	2 MHz channel bandwidth	230	230	239.5							mA
	4 MHz channel bandwidth	237.5	240	249							mA
	8 MHz channel bandwidth	254	253	267							mA
Active receive MCS0	1 MHz channel bandwidth	228	226	237	4	4.5	4.7				mA
	2 MHz channel bandwidth	229.5	228	238.5							mA
	4 MHz channel bandwidth	236	236	247							mA
	8 MHz channel bandwidth	250	248	262.5							mA

Sleep power consumption

Mode	Condition	VBAT Current			VDD_FEM Current			Unit
		Min.	Typ.	Max.	Min.	Typ.	Max.	
Deep sleep	VCC/VCC_WIFI/ VDD_FEM =3.3V RC Oscillator on, wake up timer configurable	20.8	201	711.8	0.001	0.05	0.55	μA

3.4 RF Specifications

Receiver

Sensitivities for 10% packet error rate, 1000-byte packets:

MCS index	Modulation scheme	Coding rate	Channel Bandwidth				Minimum receive sensitivity (dBm) per bandwidth			
			1 MHz	2 MHz	4 MHz	8 MHz	1 MHz	2 MHz	4 MHz	8 MHz
0	BPSK	1/2	333	722	1500	3250	-105	-103	-101	-97
1	QPSK	1/2	667	1444	3000	6500	-102	-100	-97	-93
2	QPSK	3/4	1000	2167	4500	9750	-99	-97	-95	-91
3	16-QAM	1/2	1333	2889	6000	13000	-96	-94	-91	-88
4	16-QAM	3/4	2000	4333	9000	19500	-93	-90	-88	-85
5	64-QAM	2/3	2667	5778	12000	26000	-89	-87	-84	-80
6	64-QAM	3/4	3000	6500	13500	29250	-88	-85	-83	-79
7	64-QAM	5/6	3333	7222	15000	32500	-87	-84	-81	-77
10	BPSK	1/2 x 2	167	N/A			-107	N/A		

Transmitter

Although the following transmit power levels are IEEE 802.11ah compliant, they do not take into account any backoffs needed to adhere to regional spectrum compliance (e.g., FCC, IC, TELEC).

Tx output power (1/2 MHz)	Min.	Typ.	Max.	Unit
MCS 0	20	21	22	dBm
MCS 7	16	17	18	dBm

Tx output power (4 MHz)	Min.	Typ.	Max.	Unit
MCS 0	20.5	21	22	dBm
MCS 7	16	17	18	dBm

Tx output power (8 MHz)	Min.	Typ.	Max.	Unit
MCS 0	20.5	21	21.5	dBm
MCS 7	15.5	17	17.5	dBm

4. Ordering Information

Ordering No.	SoC	Main I/Os	Operating Temp.	OS
VT-SOM-AH	Morse Micro MM6108SoC & STMicroelectronics MCU	GPIO, I ² C, JTAG, U.FL, UART, CAN, ADC, USB	-40°C ~ +85°C	RTOS

Packing list	
VT-SOM-AH system-on- module	1

Optional accessory	
Wi-Fi HaLow antenna	1

5. Company Profile

Since its establishment in 2002 by two Silicon Valley entrepreneurs, Vantron Technology has been at the forefront of the connected IoT devices and IoT platform solutions. Today, Vantron boasts a global customer base that includes several Fortune 500 companies. Its product lines cover edge intelligent hardware, IoT communication devices, industrial displays and BlueSphere cloud device management platforms.

With over 20 years of experience in R&D of embedded edge intelligent hardware, Vantron has provided users with diverse embedded solutions featuring ARM and X86 architectures. Its offerings range from Linux to Windows, from embedded to desktop level, and from gateway to server. In addition, it provides users with system clipping, driver transplantation and other related services.