

VT-SBC-SMARC-8MP

Computer-on-Module



Product Brief Introduction

VT-SBC-SMARC-8MP Computer-on-Module features a SMARC form factor that is easy to integrate. It is powered by NXP i.MX8M Plus high-performance processor that is very versatile presenting multiple displays and high-speed interfaces as well as multiple memory interfaces. With both wired and wireless network accesses available, user data is kept safe and secure. Meanwhile, the core board supports robust control networks to meet different application scenarios of industry 4.0 including smart retail, self-service terminals, industrial automation, intelligent medical health, and digital media.

Featuring high flexibility and high performance, the core board could work under extreme environments with extended temperatures ranging from -20°C to +70°C (-40°C to +85°C optional), making it a reliable industrial IoT solution.

Exterior and Features

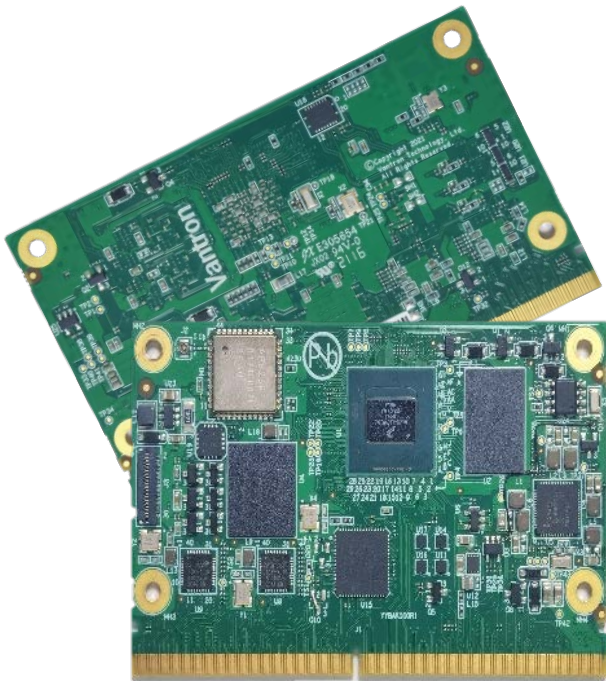

VT-SBC-SMARC-8MP

-  NXP i.MX8M Plus processor
-  Linux operating system
-  2GB LPDDR4
-  Multiple displays
-  Rich interfaces, flexible expansion
-  Ethernet/Wi-Fi & BT
-  USB 2.0 & USB 3.0
-  Wide temperature range supported

VT-SBC-SMARC-8MP Computer-on-Module Datasheet

VT-SBC-SMARC-8MP			
System	CPU	NXP i.MX8M Plus, ARM Cortex-A53, Dual- or Quad-core, 1.8GHz-2.0GHz	
	Memory	2GB LPDDR4	
	Storage	16GB eMMC 5.1 1 x SDIO	
Communication	Ethernet	2 x 100Mbps	
	Wi-Fi & BT	Wi-Fi 802.11 a/b/g/n/ac + BT5.0	
Media	Display	1 x MIPI DSI	
		2 x LVDS 1 x HDMI 2.0a	
	Camera	2 x MIPI CSI	
I/Os	Serial	1 x UART with CTS/RTS 2 x UART without CTS/RTS	
	USB	1 x USB OTG 2 x USB 2.0 2 x USB 3.0	
		GPIO	14 x GPIO
		Bus	1 x PCIe 4 x I ² C 2 x I ² S (for audio) 2 x SPI
	RTC	Supported	
	System Control	PWM	1 x PWM
Power	Input	5V DC, Powered by carrier board	
Software	Operating system	Linux	
Mechanical	Dimensions	82mm x 50mm SMARC 2.1	
Environment Condition	Temperature	Operating: -20°C~+70°C (Optional: -40°C~+85°C) Storage: -40°C~+85°C	
	Humidity	5%-95%RH (non-condensing)	

Product Outlines

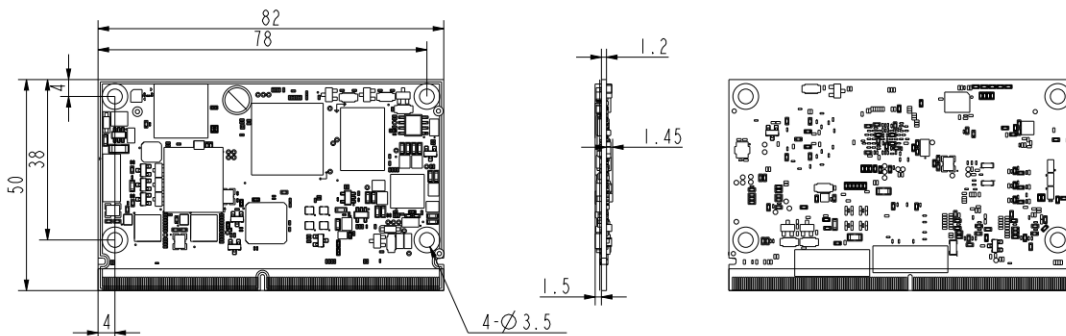

Block Diagram

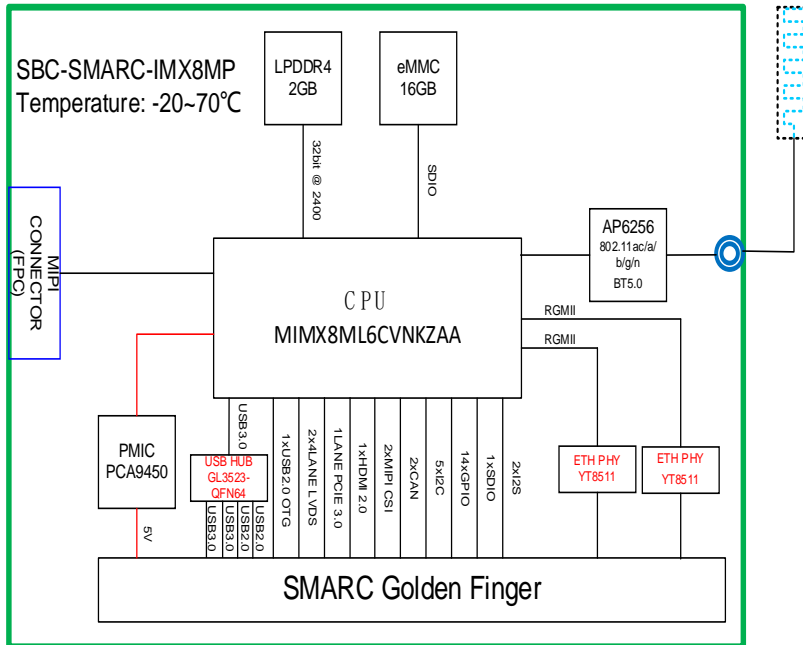

Company Profile

Since 2002 established by two Silicon Valley entrepreneurs, Vantron Technology has been a pioneer in connected IoT devices and IoT platform solutions. Today, Vantron serves countless customers all over the world, some of them are Fortune 500 companies. Products lines cover edge intelligent hardware, IoT communication devices, industrial displays and BlueSphere cloud device management platform.

Vantron has 20 years of experience in R&D of embedded edge intelligent hardware like SOM board and motherboard, and provided users with various embedded solutions with ARM and X86 architecture. From Linux to Windows, from embedded to desktop level, from gateway to server. At the same time, we provide our users with system clipping, driver transplantation and other services.

Vantron IoT communication devices support multi-protocol connection of industrial equipment, edge computing of local data. Abundant wired and wireless connectivity make remote operations and maintenance possible. From electricity and transportation to smart retail, medical and warehousing, Vantron IoT communication device can be deployed anywhere in any business section. Vantron believes its IoT solution to help many companies finish their digital transformation, efficiency of manufacturing and productivities have been improved significantly.

Vantron industrial display systems, ARM and X86 series, are equipped with Rockchip, NXP, MediaTek, Intel and other high-performance processors. It supports various operating systems such as Windows, Linux, and Android. Diverse wireless communications keep your device online all the time. Multiple installation methods make it suitable for a variety of application scenarios. Features like waterproof, dustproof, shatter resistant guarantee the best performance in any environment.

Vantron BlueSphere device management platform, a software product, is playing a big role in Vantron overall IoT solution. Today, Vantron puts more focus on offering complete cost effective, leading-edge yet reliable solutions to help customers carry out their visions.