

VT-SBC-3568-GEN2

Single Board Computer

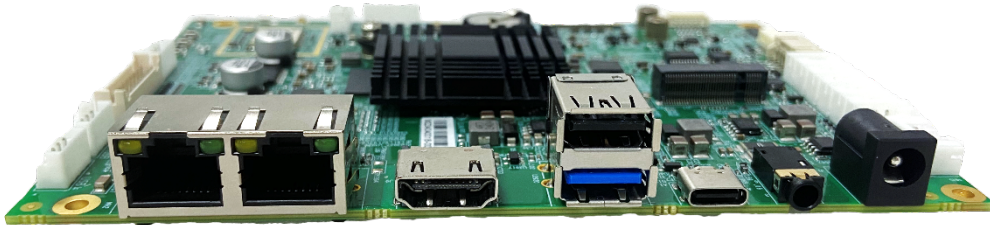

User Manual

Version: 1.7

© Vantron Technology, Inc. All rights reserved.

Revision History

No.	Version	Description	Date
1	V1.0	First release	Jan. 14, 2022
2	V1.1	Updated pinout description of GPIO	Jun. 16, 2022
3	V1.2	Added a chapter for Yocto project development	Mar. 3, 2023
4	V1.3	Added Android system description and updated the typesetting	Jun. 2, 2023
5	V1.4	Updated the debugging instructions on UART & GPIO in Debian system	Nov. 28, 2023
6	V1.5	Upgraded the manual as per the new hardware design including dual Ethernet jacks, upgraded serial ports, GPIO, and CAN	Jul. 22, 2024
7	V1.6	Updated the Debian system manual	Feb. 13, 2025
8	V1.7	Updated the pin out for the eDP connector	Jun. 17, 2025

Table of Contents

Foreword.....	1
CHAPTER 1 INTRODUCTION	5
1.1 Product Overview	6
1.2 Product Feature	6
1.3 Terminology/Acronym.....	7
1.4 Block Diagram	8
1.5 Specifications	9
1.6 Operating system	10
1.7 Mechanical Dimensions	10
1.8 Power Supply and Consumption.....	10
1.9 Environmental Specifications.....	10
CHAPTER 2 HARDWARE DESCRIPTION	11
2.1 Product Layout	12
2.2 Memory and Storage	12
2.2.1 LPDDR4 RAM.....	12
2.2.2 eMMC Flash	12
2.2.3 EEPROM	12
2.3 Identification of Pin 1.....	13
2.4 Connectors and Jumpers.....	13
2.4.1 J1/J107 Power input (1)	13
2.4.2 U3925 Ethernet port (2).....	14
2.4.3 U39 Wi-Fi and Bluetooth (3)	14
2.4.4 J9 HDMI (4)	14
2.4.5 J104 eDP (5)	15
2.4.6 J10 MIPI DSI/LVDS (6).....	16
2.4.7 J105 Backlight connector (7).....	18
2.4.8 J8 MIPI CSI (8)	18
2.4.9 J22 I ² C (9)	20
2.4.10 U3920 USB Type-A (10).....	20
2.4.11 J3/J4/J5 USB 2.0 (11).....	21
2.4.12 J7 USB 2.0 Type-C (12)	21
2.4.13 J101/J102/J103 RS232/RS485 (13).....	22
2.4.14 J33/J32 UART (14)	23
2.4.15 J31/J031 CAN (15).....	23
2.4.16 J21 GPIO (16).....	24
2.4.17 J16 Audio jack (17)	25
2.4.18 J15 Speaker (18).....	25
2.4.19 J100 A-Mic/D-Mic (19).....	26
2.4.20 J17 M.2 Key B slot (20).....	26
2.4.21 Buttons (21)	27
2.4.22 J18 Micro SIM (22)	27
2.4.23 RTC.....	27

CHAPTER 3	ANDROID SYSTEM MANUAL	28
3.1	Enable Developer Options	29
3.2	ADB Setup on the Windows Host	29
3.3	App Installation via ADB Commands	31
3.4	Network Connectivity	32
3.4.1	Ethernet	32
3.4.2	Wi-Fi	33
3.4.3	Cellular	33
3.5	Peripheral I/Os	34
3.5.1	RS232/RS485	34
3.5.2	UART	35
3.5.3	CAN	36
3.5.4	GPIO	36
3.6	Firmware Upgrade in Windows Environment	37
3.7	Firmware Upgrade in Ubuntu Environment	39
CHAPTER 4	DEBIAN SYTEM MANUAL	40
4.1	About the Device	41
4.1.1	Device information	41
4.1.2	System settings	42
4.1.3	EEPROM	42
4.1.4	RTC	43
4.2	Network Connectivity	44
4.2.1	Ethernet	44
4.2.2	Wi-Fi	45
4.2.3	Pairing with a Bluetooth device	45
4.2.4	Sending a file to a Bluetooth device	46
4.2.5	Cellular	46
4.3	Peripheral I/Os	47
4.3.1	USB	47
4.3.2	RS232/RS422/RS485	48
4.3.3	UART	49
4.3.4	CAN	50
4.3.5	GPIO	50
4.3.6	Audio	51
4.3.7	Video	52
4.3.8	Camera	52
CHAPTER 5	DISPOSAL AND PRODUCT WARRANTY	53
5.1	Disposal	54
5.2	Warranty	55

Foreword

Thank you for purchasing VT-SBC-3568-GEN2 single board computer (“the Board” or “the Product”). This manual intends to provide guidance and assistance necessary on setting up, operating or maintaining the Product. Please read this manual and make sure you understand the functionality of the Product before putting it into use.

Intended Users

This manual is intended for:

- Embedded software developer
- Custom development software engineer
- Other technically qualified personnel

Copyright

Vantron Technology, Inc. (“Vantron”) reserves all rights of this manual, including the right to change the content, form, product features, and specifications contained herein at any time without prior notice. An up-to-date version of this manual is available at www.vantrontech.com.

The trademarks in this manual, registered or not, are properties of their respective owners. Under no circumstances shall any part of this user manual be copied, reproduced, translated, or sold. This manual is not intended to be altered or used for other purposes unless otherwise permitted in writing by Vantron. Vantron reserves the right of all publicly released copies of this manual.

Disclaimer

While all information contained herein has been carefully checked to assure its accuracy in technical details and typography, Vantron does not assume any responsibility resulting from any error or features of this manual, nor from improper uses of this manual or the software.

It is our practice to change part numbers when published ratings or features are changed, or when significant construction changes are made. However, some specifications of the Product may be changed without notice.

Technical Support and Assistance

Should you have any question about the Product that is not covered in this manual, contact your sales representative for solution. Please include the following information in your question:

- Product name and PO number;
- Complete description of the problem;
- Error message you received, if any.

Vantron Technology, Inc.



Address: 48434 Milmont Drive, Fremont, CA 94538

Tel: (650) 422-3128

Email: sales@vantrontech.com

Symbology

This manual uses the following signs to prompt users to pay special attention to relevant information.







	Caution for latent damage to system or harm to personnel
	Attention to important information or regulations

General Safety Instructions

The Product is supposed be installed by knowledgeable, skilled persons familiar with local and/or international electrical codes and regulations. For your safety and prevention of damage to the Product, please read and observe carefully the following safety instructions prior to installation and operation. Keep this manual well for future reference.

- Do not disassemble or otherwise modify the Product. Such action may cause heat generation, ignition, electronic shock, or other damages including human injury, and may void your warranty.
- Keep the Product away from heat source, such as heater, heat dissipater, or engine casing.
- Do not insert foreign materials into any opening of the Product as it may cause the Product to malfunction or burn out.
- To ensure proper functioning and prevent overheating of the Product, do not cover or block the ventilation holes of the Product.
- Follow the installation instructions with the installation tools provided or recommended.
- The use or placement of the operation tools shall comply with the code of practice of such tools to avoid short circuit of the Product.
- Cut off the power before inspection of the Product to avoid human injury or product damage.

Precautions for Power Cables and Accessories

-  Use proper power source only. Make sure the supply voltage falls within the specified range.
-  Place the cables properly at places without extrusion hazards.
-  There is a coin cell battery for powering the RTC. Therefore, please avoid short circuit of the battery during transportation or operation at high temperatures.
-  Cleaning instructions:
 - Power off before cleaning the Product
 - Do not use spray detergent
 - Clean with a damp cloth
 - Do not try to clean exposed electronic components unless with a dust collector
-  Power off and contact Vantron technical support engineer in case of the following faults:
 - The Product is damaged
 - The temperature is excessively high
 - Fault is still not solved after troubleshooting according to this manual
-  Do not use in combustible and explosive environment:
 - Keep away from combustible and explosive environment
 - Keep away from all energized circuits
 - Unauthorized removal of the enclosure from the device is not allowed
 - Do not change components unless the power cable is unplugged
 - In some cases, the device may still have residual voltage even if the power cable is unplugged. Therefore, it is a must to remove and fully discharge the device before replacement of the components.

CHAPTER 1 INTRODUCTION

1.1 Product Overview

VT-SBC-3568-GEN2 single board computer is an enhanced version of original VT-SBC-3568, featuring updated hardware design that includes dual Ethernet jacks, upgraded serial ports, GPIO, and CAN support. It comes in a 3.5-inch form factor that is compact for flexible integration. It is powered by Rockchip RK3568 processor, which integrates a quad-core ARM Cortex-A55 CPU, a high-performance ARM Mali-G52 GPU, and an NPU with up to 1 TOPS computing performance, enhancing its capabilities in image recognition, edge computing, and more. It provides different display interfaces and supports up to three displays in extended mode. With support for H.265/H.264 video codec formats, the board can deliver optimized video output performance.

In terms of connectivity, VT-SBC-3568-GEN2 offers dual gigabit Ethernet jacks for wired connection, along with wireless options such as Wi-Fi, Bluetooth, and optional 4G/5G, ensuring secure and uninterrupted communication. The on-board 4GB memory and 32GB storage, with expansion options, provide ample resources. Moreover, it provides rich interfaces such as USB, UART, I2C, CAN, GPIO, offering flexible user expansion options. The board is ideal for application in a variety of scenarios, such as video conference, smart security, commercial display, edge computing, smart home, and industrial automation.

1.2 Product Feature

- RK3568, Quad-core ARM Cortex-A55 processor
- Default 4GB memory + 32GB storage, expansion support
- H.264/H.265 decoder by 4K @60fps, H.264/H.265 encoder by 1080p @60fps
- Up to three displays in extended mode
- 4K UHD (3840 x 2160) HDMI video output
- Dual Gigabit Ethernet, Wi-Fi, BT 5.0, optional 4G/5G connectivity
- Rich interfaces for flexible expansion (GPIO, CAN, RS232/RS485, internal USB, I²C)
- Up to 1 TOPS processing performance, with support for mainstream AI frameworks
- 3.5-inch form factor for easy integration

1.3 Terminology/Acronym

Please refer to the table below for acronyms or terminologies used in this document, especially for those included in the pinout description of the device.

Terminology/Acronym	Description
NC	<i>No connection</i>
VCC	Voltage common collector
GND	Ground
P (+)	Positive difference signal
N (-)	Negative difference signal
SCL	Serial clock
SDA	Serial data
I	Input
O	Output
I/O	Input/output
P	Power/ground
RX	Receive data
TX	Transmit data
PCIe	PCI express signal
MDI	Media dependent interface
INT	Interrupt
RST	Reset
MISO	Master in slave out
MOSI	Master out slave in

1.4 Block Diagram

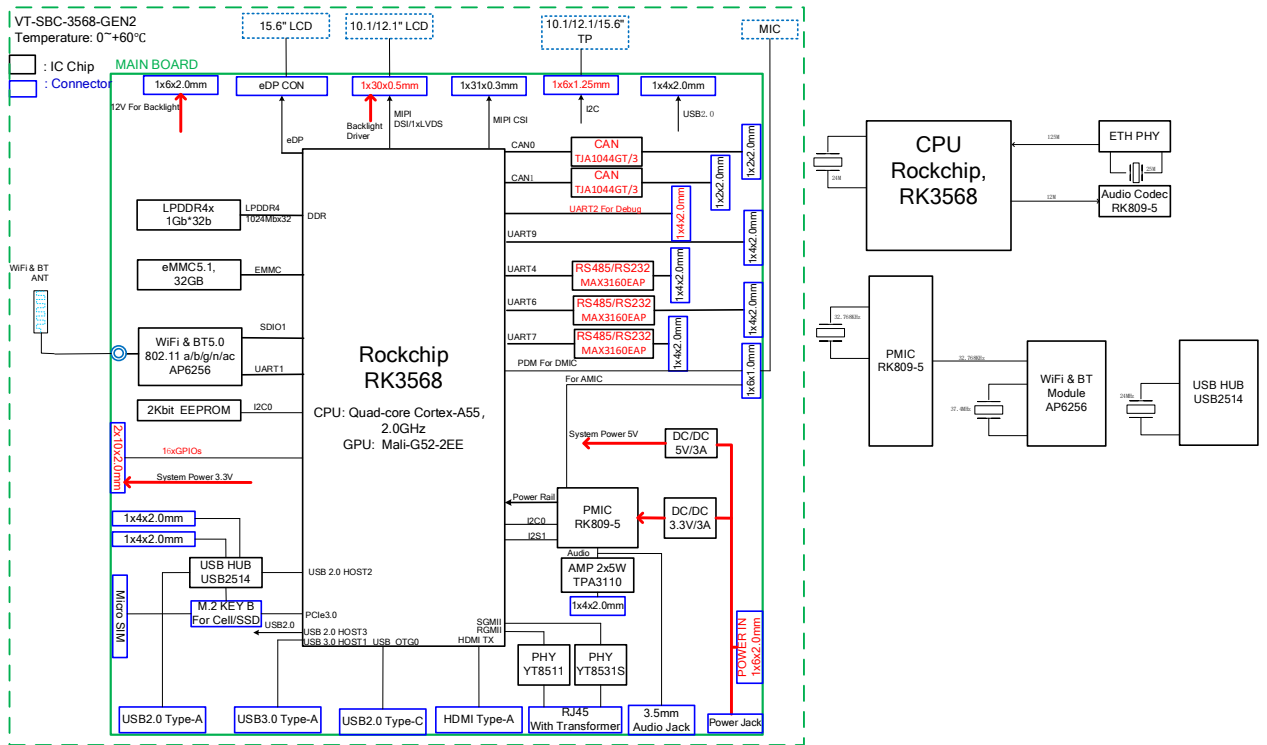

1.5 Specifications

VT-SBC-3568-GEN2			
System	CPU	RK3568, Quad-core ARM Cortex-A55 MPCore, up to 2.0 GHz	
	GPU	ARM Mali-G52, 600MHz H.264/H.265 decoder by 4K@60fps, H.264/H.265 encoder by 1080p@60fps	
	NPU	Up to 1 TOPS performance	
	Memory	4GB LPDDR4 (Optional: 8GB)	
	Storage	32GB eMMC V5.1 (Optional: 64GB)	2Kb EEPROM
Communication	Ethernet	2 x RJ45, 10/100/1000Mbps 100Base-T4	
	Cellular	Optional: 4G/5G (expansion by an M.2 B-Key)	
	Wi-Fi & BT	Wi-Fi 802.11 a/b/g/n/ac + Bluetooth 5.0	
Media	Display (Extended mode)	1 x HDMI 2.0, up to 4K @60Hz	1 x MIPI DSI/LVDS, up to 1920 x 1080 @60Hz
		1 x eDP, up to 1920 x 1080 @60Hz	@60Hz
	Camera	1 x 4-lane MIPI CSI, 5MP	
	Audio	1 x 3.5mm Combo audio jack	2 x 4W/8Ω Speaker connector
1 x DMIC		1 x AMIC	
I/Os	Serial port	1 x UART (3.3V)	3 x RS232/RS485 (9600, 8N1)
		1 x Debug UART (3.3V)	
	USB	1 x USB 3.0 Type-A	1 x USB 2.0 Type-C (OTG)
		1 x USB 2.0 Type-A	3 x USB 2.0 connector
	Bus	2 x CAN, with transmitter	1 x I ² C for TP
	GPIO	18 x GPIO (3.3V)	
	SIM slot	1 x Micro SIM slot	
	RTC	Supported	
WDT	Supported		
Expansion	M.2	1 x M.2 B-key, (3052) USB 2.0 for 4G/5G, or (2242) PCIe for SSD	
System Control	Button	1 x Reset	1 x Recovery button
		1 x Power button	
Power	LED indicator	1 x Power indicator	1 x System running indicator
Power	Input	12V/3A DC	
		1 x Power jack, 1 x Power connector	
Software	Operating system	Android 11, Debian 11	
	Device management platform	BlueSphere MDM (Optional for Android version)	
Mechanical	Dimensions	146.02mm x 102mm	
	Cooling mode	Fanless	
Environment Condition	Temperature	Operating: 0°C~+60°C (Optional: -40°C~+85°C)	
		Storage: -20°C~+80°C (Optional: -55°C~+85°C)	
	Humidity	≤95% RH (Non-condensing)	

1.6 Operating system

VT-SBC-3568-GEN2 supports Debian 11 and Android 11 operating systems.

1.7 Mechanical Dimensions

- 146.02mm x 102mm x 17.2mm

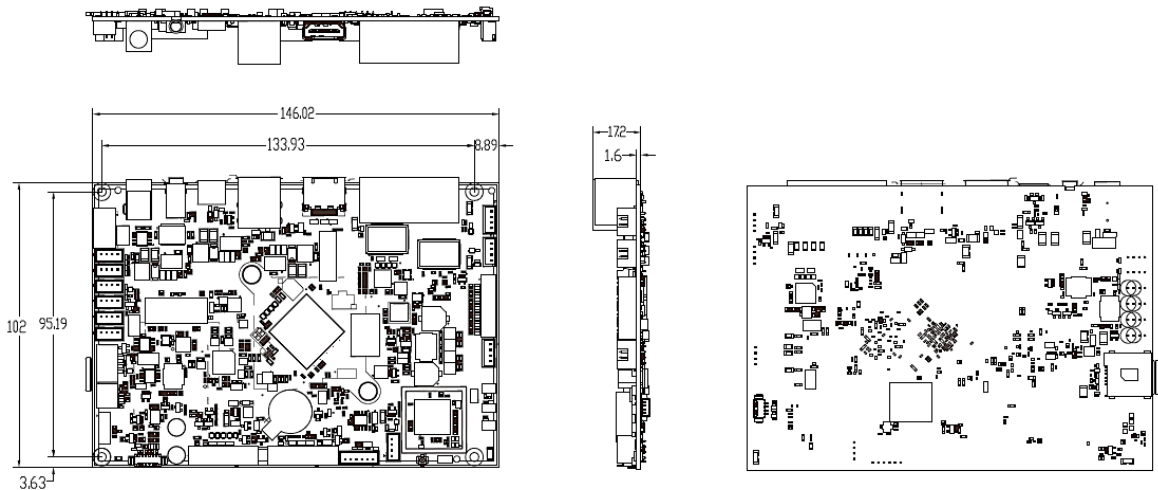

1.8 Power Supply and Consumption

VT-SBC-3568-GEN2 works with 12V/3A DC power supply.

The power consumption of the board is about 30W at the maximum. It should be pointed out that power consumption is largely determined by the RAM, storage capacity, peripherals, and other configurations of the board.

1.9 Environmental Specifications

VT-SBC-3568-GEN2 works at a temperature ranging from 0°C to +60°C, with an option for -40°C to +85°C and is designed to be stored at a temperature ranging from -20°C to +80°C, with an option for -55°C~+85°C. It is designed to work and be stored at a relative humidity of no more than 95% RH for non-condensing purpose.

CHAPTER 2 HARDWARE DESCRIPTION

2.1 Product Layout

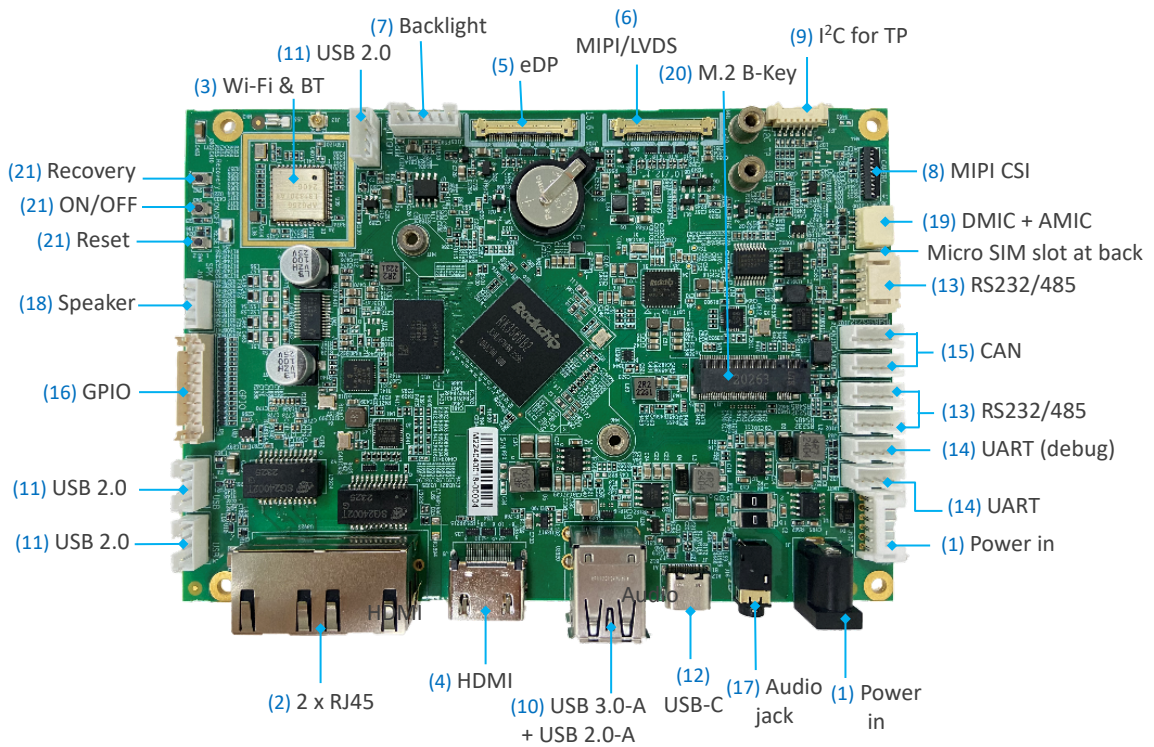

▶ The board I/Os will be described in detail in 2.4 Connectors and Jumpers following the sequencing numbers provided here.

2.2 Memory and Storage

2.2.1 LPDDR4 RAM

VT-SBC-3568-GEN2 is equipped with a 4GB LPDDR4 RAM by default, and users also have the option of 8GB RAM.

2.2.2 eMMC Flash

VT-SBC-3568-GEN2 provides an eMMC 5.1 flash, offering a default capacity of 32GB, with option for 64GB. It is used as the default boot and storage device.

2.2.3 EEPROM

VT-SBC-3568-GEN2 provides a 2Kb EEPROM to store hardware configuration information.

2.3 Identification of Pin 1

Unless otherwise stated, pin 1 of a connector is seated on a square pad that is different from the round pads used for other pins. Sometimes, pin 1 is next to a trigonal mark on the board. When there are two rows of pins on a connector, the row with pin 1 is composed of odd numbers and the other is composed of even numbers.



Usually, there will be numbers or marks next to the pins of a connector on the board to indicate the pinouts.



2.4 Connectors and Jumpers

This section is going to brief the connectors/jumpers on the Board with responsive pinout description.

2.4.1 J1/J107 Power input (1)

VT-SBC-3568-GEN2 provides a 4-pin power connector and a power jack to supply power for the Board.

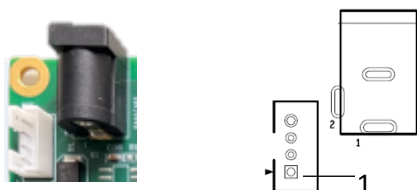

Pinout description of the 4-pin power connector:

Pin	Name	Type	Description
1	+VDC	P	DC-IN POWER +
2	+VDC	P	DC-IN POWER +
3	-VDC	P	DC-IN POWER -
4	-VDC	P	DC-IN POWER -

2.4.2 U3925 Ethernet port (2)

VT-SBC-3568-GEN2 offers two RJ45 Ethernet jacks with two LEDs, green for activity indication and yellow for link indication. The ports support 10/100/1000Mbps transmission rate.

The two Ethernet jacks are designated as WAN ports, intended for connecting to a router or switch to establish Internet access. They support automatic failover in case of a network failure. The Ethernet jacks are mapped as eth1 and eth0, respectively in the system.

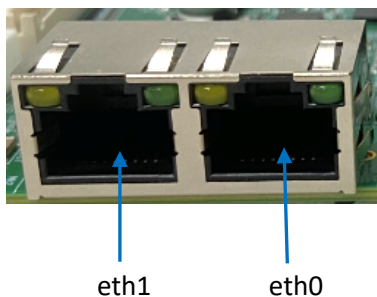

2.4.3 U39 Wi-Fi and Bluetooth (3)

VT-SBC-3568-GEN2 offers an AP6256 1T1R combo SiP module, combining Wi-Fi 802.11 a/b/g/n/ac and Bluetooth 5.0. The module offers an SDIO interface for Wi-Fi and an UART for Bluetooth. There is an antenna interface next to the module for connecting the Wi-Fi & Bluetooth antenna.

2.4.4 J9 HDMI (4)

VT-SBC-3568-GEN2 offers a standard HDMI Type-A interface for up to 4K at 60Hz image output. The pinout description of the interface is in line with the pin assignment of a standard HDMI Type-A interface.

2.4.5 J104 eDP (5)

VT-SBC-3568-GEN2 offers an eDP interface for connecting high-definition displays, with a resolution up to 1920 x 1080.

Specification: 1 x 30, 0.5mm, female, SMT, wire to board

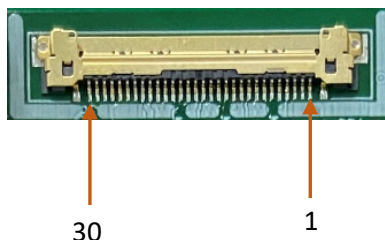

Pinout description:

Pin	Name	Type	Description
1	eDP_3V3	P	3.3V LCD power supply
2	eDP_3V3	P	3.3V LCD power supply
3	eDP_3V3	P	3.3V LCD power supply
4	HPD	I	Hot plug detection
5	GND	P	GND
6	eDP1_TX0N_PORT	O	eDP transmit differential data lane 0 negative
7	eDP1_TX0P_PORT	O	eDP transmit differential data lane 0 positive
8	GND	P	GND
9	eDP1_TX1N_PORT	O	eDP transmit differential data lane 1 negative
10	eDP1_TX1P_PORT	O	eDP transmit differential data lane 1 positive
11	GND	P	GND
12	eDP1_TX2N_PORT	O	eDP transmit differential data lane 2 negative
13	eDP1_TX2P_PORT	O	eDP transmit differential data lane 2 positive
14	GND	P	GND
15	eDP1_TX3N_PORT	O	EDP transmit differential data lane 3 negative

Pin	Name	Type	Description
16	eDP1_TX3P_PORT	O	eDP transmit differential data lane 3 positive
17	GND	P	GND
18	eDP_TX_AUXN_PORT	O	eDP AUX differential negative
19	eDP_TX_AUXP_PORT	O	eDP AUX differential positive
20	GND	P	GND
21	GND	P	GND
22	LCD_eDP_BL_EN_H_J	O	eDP LCD backlight power control output, active high
23	LCD_eDP_BL_PWM_J	O	LVDS/eDP LCD backlight PWM control output
24	GND	P	GND
25	GND	P	GND
26	GND	P	GND
27	NC		
28	eDP_BL_12V	P	Backlight power
29	eDP_BL_12V	P	Backlight power
30	eDP_BL_12V	P	Backlight power

2.4.6 J10 MIPI DSI/LVDS (6)

VT-SBC-3568-GEN2 offers a 4-lane MIPI DSI connector that is multiplexed as an LVDS interface for connecting displays.

Specification: 1 x 30, 0.5mm, female, SMT, wire to board

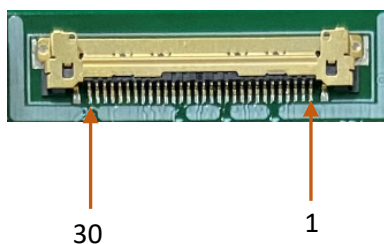

Pinout description:

Pin	Name	Type	Description
1	NC		
2	VCC3V3_LCD	P	3.3V power supply
3	VCC3V3_LCD	P	3.3V power supply
4	NC		
5	LVDS_HFRC_EN	I	MIPI/LVDS input detection, low for MIPI, high for LVDS
6	RST_LCD	O	MIPI LCD reset control output, active low
7	NC		
8	GND	G	GND
9	MIPI_D3N/LVDS_D3N	O	MIPI/LVDS differential lane 3 negative
10	MIPI_D3P/LVDS_D3P	O	MIPI/LVDS differential lane 3 positive
11	GND	P	GND
12	MIPI_D0N/LVDS_D0N	O	MIPI/LVDS differential lane 0 negative
13	MIPI_D0P/LVDS_D0P		MIPI/LVDS differential lane 0 positive
14	GND	P	GND
15	MIPI_CLK-/LVDS_CLK-	O	MIPI/LVDS differential clock lane negative
16	MIPI_CLK+/LVDS_CLK+	O	MIPI/LVDS differential clock lane positive
17	GND	P	GND
18	MIPI_D1N/LVDS_D1N	O	MIPI/LVDS differential lane 1 negative
19	MIPI_D1P/LVDS_D1P	O	MIPI/LVDS differential lane 1 positive
20	GND	P	GND
21	MIPI_D2N/LVDS_D2N	O	MIPI/LVDS differential lane 2 negative
22	MIPI_D2P/LVDS_D2P	O	MIPI/LVDS differential lane 2 positive
23	GND	P	
24	GND	P	
25	LED-	P	LED Cathode
26	LED-	P	LED Cathode
27	NC		
28	LED+	P	LED Anode
29	LED+	P	LED Anode
30	NC		

2.4.7 J105 Backlight connector (7)

VT-SBC-3568-GEN2 offers a backlight connector that is designed to connect a backlight to increase readability for the LCD connected to the MIPI DSI/LVDS interface in low light conditions.

Specification: 1 x 6, 2.0mm, 6mm (H), male, vertical



Pinout description:

Pin	Name	Type	Description
1	LCD_BLK	P	Power supply 12V for backlight
2	LCD_BLK	P	Power supply 12V for backlight
3	PANEL_BKLTEN	O	LCD backlight power control output
4	PANEL_BL_PWM	O	LCD backlight PWM control output
5	GND	P	Ground
6	GND	P	Ground

2.4.8 J8 MIPI CSI (8)

VT-SBC-3568-GEN2 offers a 4-lane MIPI CSI connector for connecting a camera.

Specification: 1 x 31, 0.3mm, 1.0mm (H), RA, WDT, SMT, RoHS



Pinout description:

Pin	Name	Type	Description
1	GND	P	Ground
2	MIPI_CSI_D3N	I	MIPI CSI Lane3 -
3	MIPI_CSI_D3P	I	MIPI CSI Lane3 +
4	GND	P	Ground
5	MIPI_CSI_D2N	I	MIPI CSI Lane2 -
6	MIPI_CSI_D2P	I	MIPI CSI Lane2 +
7	GND	P	Ground
8	MIPI_CSI_D1N	I	MIPI CSI Lane1 -
9	MIPI_CSI_D1P	I	MIPI CSI Lane1 +
10	GND	P	Ground
11	MIPI_CSI_D0N	I	MIPI CSI Lane0 -
12	MIPI_CSI_D0P	I	MIPI CSI Lane0 +
13	GND	P	Ground
14	MIPI_CSI_CLK0N	I	MIPI CSI CLK-
15	MIPI_CSI_CLK0P	I	MIPI CSI CLK+
16	GND	P	Ground
17	I2C2_SCL_M1_1V8	O	I2C_SCL
18	I2C2_SDA_M1_1V8	I/O	I2C_SDA
19	MIPI_RST_1V8	O	Camera reset signal, active low
20	MIPI_PDN_1V8	O	Camera power down signal, active low
21	GND	P	Ground
22	MIPI_CSI_MCLK	O	Camera main clock
23	GND	P	Ground
24	NC		
25	VCC1V8_DVP	P	Power supply 1.8V
26	VCC1V8_DVP	P	Power supply 1.8V
27	VCC1V5_DVP	P	Power supply 1.5V
28	VCC2V8_DVP	P	Power supply 2.8V
29	VCC2V8_DVP	P	Power supply 2.8V
30	NC		
31	GND	P	Ground

2.4.9 J22 I²C (9)

VT-SBC-3568-GEN2 offers an I²C interface for connecting a touch panel.

Specification: 1 x 6, 0.5mm, 0.4A, 0.9mm (H), female, RA, WDT, SMT, RoHS

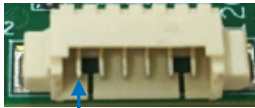

1

Pinout description:

Pin	Name	Type	Description
1	VCC_3V3	P	Power supply 3.3V
2	GND	P	Ground
3	SCL (3V3)	O	I2C_SCL for TP
4	SDA (3V3)	I/O	I2C_SDA for TP
5	INT (3V3)	I	TP interrupt
6	RST (3V3)	O	TP reset

2.4.10 U3920 USB Type-A (10)

VT-SBC-3568-GEN2 offers a USB 2.0 Type-A and a USB 3.0 Type-A in stacked configuration, allowing users to connect peripherals to expand the board function.

The pinout description of the USB interfaces is in line with the pin assignment of standard USB 2.0 Type-A and USB 3.0 Type-A.

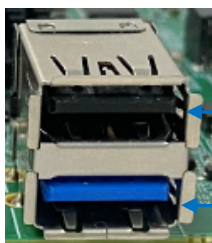

USB 2.0 Type-A

USB 3.0 Type-A

2.4.11 J3/J4/J5 USB 2.0 (11)

The board implements three USB 2.0 headers for flexibly connecting peripherals such as a USB keyboard, USB flash drive, or USB camera.

Specification: 1 x 4, 2.0mm, 2A, 6mm (H), male, RA, WDT, THR, RoHS

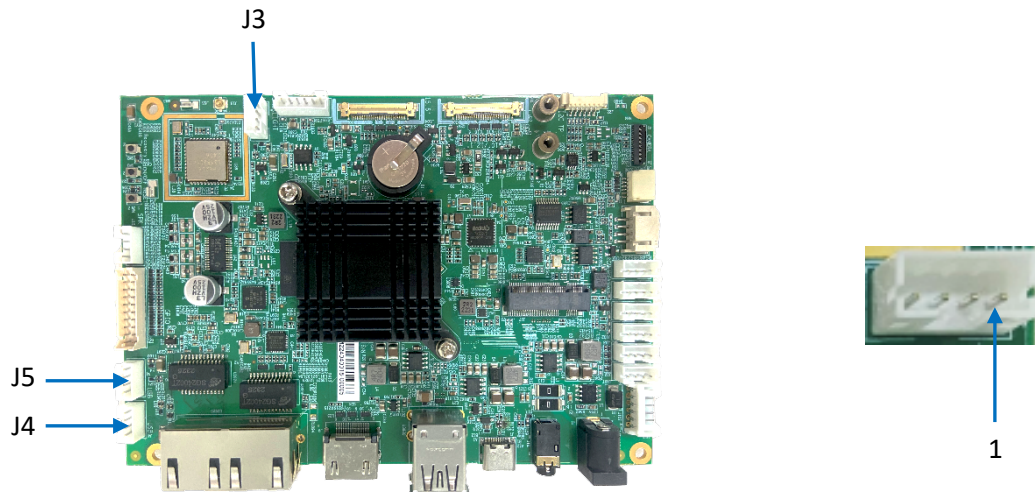

Pinout description:

Pin	Name	Type	Description
1	GND	P	Ground
2	USB_DP	I/O	USB DATA+
3	USB_DM	I/O	USB DATA-
4	VCC_5V	P	5V Power supply for USB

2.4.12 J7 USB 2.0 Type-C (12)

VT-SBC-3568-GEN2 offers a USB 2.0 Type-C OTG interface supporting a maximum current output of 0.5A. Users can use this interface for debugging or programming the board.

2.4.13 J101/J102/J103 RS232/RS485 (13)

VT-SBC-3568-GEN2 implements three RS232/RS485 multiplexers. J103 is named as UART0 and seated away from the other two headers, J102 and J101, which are named as UART4 and UART6. J103, J102, and J101 are mapped as /dev/ttyS0, /dev/ttyS4, and /dev/ttyS6, respectively in the file system.

Specification of J103: 1 x 4, 2.0mm, 2A, 5.5mm (H), male, Vert, WDT, THR, RoHS

Specification of J101/J102: 1 x 4, 2.0mm, 2A, 6mm (H), male, Vert, WDT, THR, RoHS

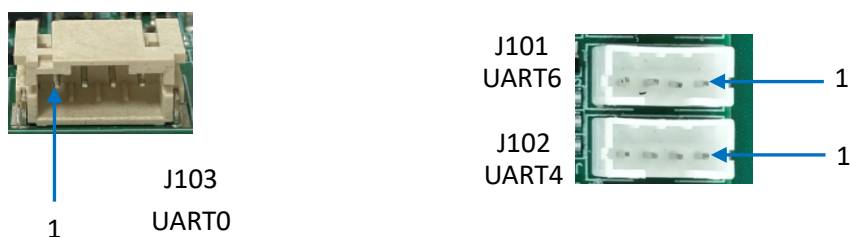

Pinout description:

Pin	Name	Type	Description
1	GND	P	Ground
2	RS232_RXD	I	RS232 receive data
3	RS485_A	I/O	RS485_A
4	RS485_B/RS232_TXD	I/O	RS485_B/RS232 transmit data

2.4.14 J33/J32 UART (14)

VT-SBC-3568-GEN2 offers two UART headers. J33 is named as UART2 for debugging the board, and J32 is named as UART9 for serial communication. They are mapped as /dev/ttyS2 and /dev/ttyS9, respectively in the file system.

Specification: 1 x 4, 2.0mm, 2A, 6mm (H), male, vert, WDT, THR, RoHS



Pinout description:

Pin	Name	Type	Description
1	GND	P	Ground
2	UART_TX	O	UART transmit data
3	UART_RX	I	UART receive data
4	VCC_3V3	P	3.3V power supply

2.4.15 J31/J031 CAN (15)

VT-SBC-3568-GEN2 offers two CAN buses. J31 is named as CAN0, and J031 is named as CAN1.

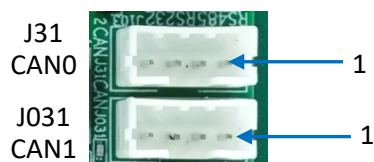

Pinout description:

Pin	Name	Type	Description
1	GND	P	Ground
2	GND	P	Ground
3	CAN_L	I/O	Low level
4	CAN_H	I/O	High level

2.4.16 J21 GPIO (16)

There is a GPIO header on the board, providing up to 18 GPIOs and user can customize the use of the pins based on need.

Specification: 2 x 10, 2.0 mm, 6.5 mm (H), Vert, -25~85°C, THR, RoHS



Pinout description:

Pin	Name	Type	Description
1	GPIO1 (3V3)	I/O	General-purpose input and output
2	GPIO2 (3V3)	I/O	General-purpose input and output
3	GPIO3 (3V3)	I/O	General-purpose input and output
4	GPIO4 (3V3)	I/O	General-purpose input and output
5	GPIO5 (3V3)	I/O	General-purpose input and output
6	GPIO6 (3V3)	I/O	General-purpose input and output
7	GPIO7 (3V3)	I/O	General-purpose input and output
8	GPIO8 (3V3)	I/O	General-purpose input and output
9	GPIO9 (3V3)	I/O	General-purpose input and output
10	GPIO10 (3V3)	I/O	General-purpose input and output
11	GPIO11 (3V3)	I/O	General-purpose input and output
12	GPIO12 (3V3)	I/O	General-purpose input and output
13	GPIO13 (3V3)	I/O	General-purpose input and output
14	GPIO14 (3V3)	I/O	General-purpose input and output
15	GPIO15 (3V3)	I/O	General-purpose input and output
16	GPIO16 (3V3)	I/O	General-purpose input and output
17	GPIO17 (3V3)	I/O	General-purpose input and output
18	GPIO18 (3V3)	I/O	General-purpose input and output
19	GND	P	Ground
20	VCC3V3	P	3.3V power supply

2.4.17 J16 Audio jack (17)

VT-SBC-3568-GEN2 offers a 3.5mm audio jack that is compatible with four-section headphone output.



2.4.18 J15 Speaker (18)

VT-SBC-3568-GEN2 offers a speaker connector that offers left and right channel stereo audio signals and is designed to connect speakers up to 15W/8Ω.

specifications: 1 x 4, 2.0mm, 2A, 6mm (H), male, vert, WDT, THR, RoHS

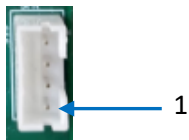

Pinout description:

Pin	Name	Type	Description
1	OUTL+A	O	Left channel speaker +
2	OUTL-A	O	Left channel speaker -
3	OUTR-A	O	Right channel speaker -
4	OUTR+A	O	Right channel speaker +

2.4.19 J100 A-Mic/D-Mic (19)

The A-Mic is for receiving acoustic signals and outputting analog signals while the D-Mic outputs digital signals and provides pre-processed digital audio stream for high-quality audio effect and noise reduction.

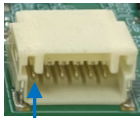

1

Pinout description:

Pin	Name	Type	Description
1	GND	P	Ground
2	GND	P	Ground
3	AMIC1_INP	I	A-mic input
4	DMIC0_DATA	I	D-mic data
5	DMIC0_CLK	I	D-mic clock
6	VCC_3V3	P	3.3V power supply

2.4.20 J17 M.2 Key B slot (20)

VT-SBC-3568-GEN2 offers an M.2 Key B slot that supports PCIe (2242) for interfacing with an SSD for storage expansion, or USB 2.0 (3052) for connecting a 4G/5G module for cellular communication.



2.4.21 Buttons (21)

VT-SBC-3568-GEN2 offers three buttons, including a Recovery button (SW2), an on/off button (SW3), and a reset button (SW4).



2.4.22 J18 Micro SIM (22)

VT-SBC-3568-GEN2 offers a Micro SIM card slot at the back of the board.

Specifications: Micro SIM, push-push, hot pluggable

2.4.23 RTC

The board offers a real-time clock for keeping track of the current time and date even when the board is turned off or rebooted. This ensures the board operates efficiently and reliably with respect to time-sensitive tasks and functions.

Specification of the battery:

Nominal voltage: 3V; nominal capacity: 35mAh; continuous drain: 0.1mA; operating temperature: -30°C ~ +85°C.

CHAPTER 3 ANDROID SYSTEM MANUAL

VT-SBC-3568-GEN2 is running Android 11 operating system. In order to test the functionality of the board described in this chapter, you are advised to connect the board to a mouse, keyboard, and monitor for easier operations.

3.1 Enable Developer Options

The Developer Options feature on VT-SBC-3568-GEN2 grants more control and access to tools that are crucial for app development, debugging, and optimizing device performance. You can follow the steps below to enable the feature:

1. Power on the board and swipe up to access the application drawer;
2. Navigate to **Settings > About tablet**;
3. Scroll down to **Build number**, and click it consecutively for at least 7 times until you see a prompt indicating you are now a developer;
4. Go back to **Settings > System > Advanced > Developer options** and toggle on **USB debugging** (under the DEBUGGING sub-menu), then you can customize the board settings.

 Generally, the USB debugging option is enabled by default once you activate Developer Options.

3.2 ADB Setup on the Windows Host

Android Debug Bridge (ADB) is a tool that is designed to connect your development workstation directly to your Android device for debugging, device upgrading, app installation, etc.

Adding the ADB executable file to the system's environment variable allows you to run the ADB tool regardless of your current working directory.

Follow the steps below to set up the ADB on the Windows host computer.

1. Unzip the software release package and navigate to the following directory: \SW\tools;
2. Extract the **adb_fastboot_and_other_tools_for_windows** zip file;
3. Navigate to the **Android** folder that contains the ADB tool kit and copy the folder path;
4. Press "Win + R" and input `sysdm.cpl` in the dialogue box to open the settings interface;

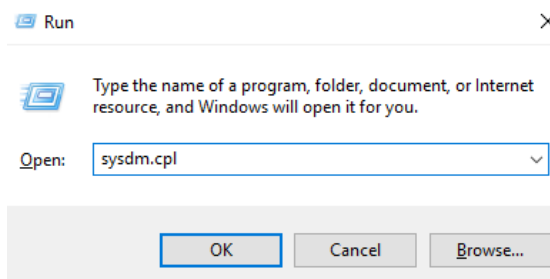

5. Click in sequence **Advanced > Environment Variables > System Variables > Path > Edit**, and click **New** in the pop-up;

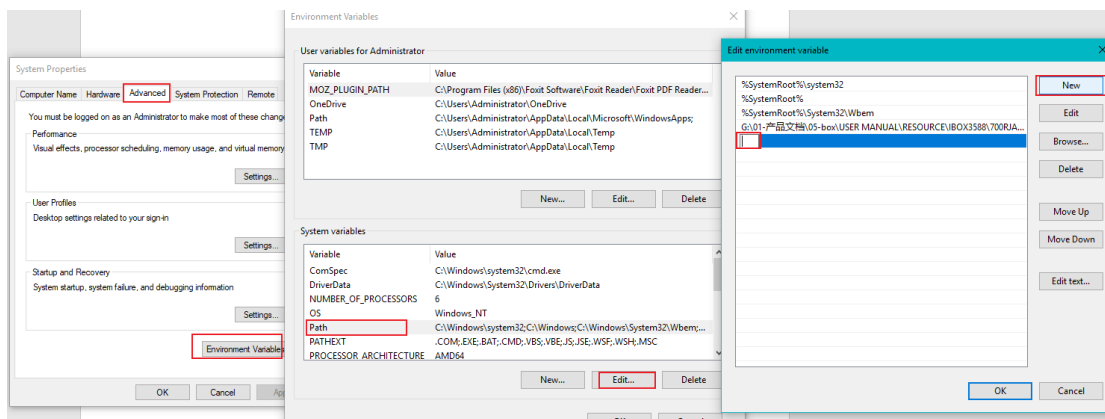

6. Paste the folder path of the **Android** folder, and click **OK** one by one to confirm and exit the dialog;

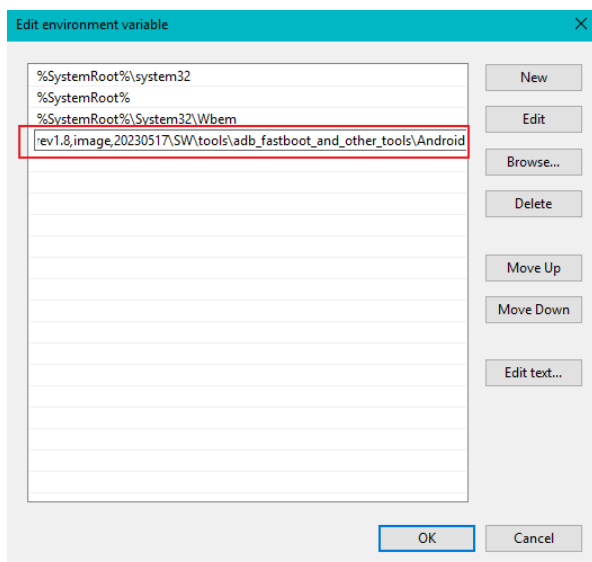

7. Press "Win + R" and input **cmd** in the dialogue box to open the command prompt;
8. Input **adb version** in the command prompt to check if the ADB tool is installed.

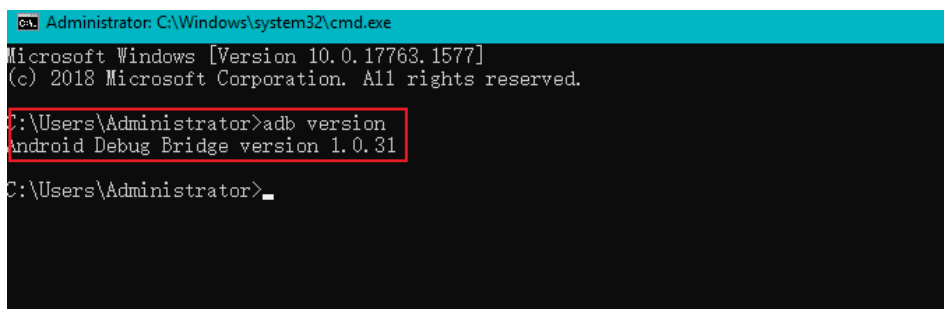

3.3 App Installation via ADB Commands

In addition to the pre-installed Android applications, users can install their own applications on the board, provided that the ADB toolkit is installed and accessible on the host computer. The following steps are carried out on a Windows computer.

1. Connect VT-SBC-3568-GEN2 to the host computer via a USB Type-A to Type-C cable;
2. Press “Win + R” and input `cmd` in the dialogue box to open the command prompt;
3. Input `adb devices -l` in the command prompt to check if the board is connected to the host computer;

```
C:\Users\Administrator>adb devices -l
List of devices attached
874cc0aaede7d049    device product:occam model:Nexus_4 device:mako transport_id:1
```

4. When the device information is displayed under the command, you can copy the serial number (squared as shown above) for next-step use;
5. Input the following command line to install the app;

```
adb -s <serial number> install <APP path>
```

6. The installation will be executed after the command is input and the result of installation will be displayed below;

```
C:\Users\Administrator>adb -s 674cc0aaede7d049 install "C:\Users\Administrator\Desktop\Libraries for developers_v3.83_apkpure.com.apk"
Performing Streamed Install
Success
```

7. The newly installed app will be displayed on the App drawer in the Alphabetic order.

 *The screenshot is for illustration only and is not intended to represent the actual device number and other information of the device currently in your possession.*

 *In step 5 shown above, you can drag the .apk file from the local directory to the command line to replace the <App path> you typed in manually.*

 *If you failed to install the apk, try using the absolute path of the .apk file enclosed in double quotation marks.*

3.4 Network Connectivity

VT-SBC-3568-GEN2 follows a networking priority of Ethernet > Wi-Fi > 4G/5G.

3.4.1 Ethernet

VT-SBC-3568-GEN2 offers two RJ45 Ethernet jacks, designated as WAN ports for connecting to a router or switch to establish Internet access.

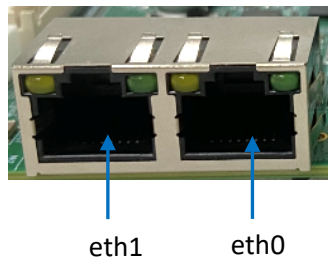

The Ethernet jacks are mapped as eth1 and eth0, respectively in the system. You can view and configure the port information after accessing the system network settings.

1. Plug one end of an Ethernet cable into a router or switch and the other end into an Ethernet jack on the board;
2. Navigate to **App drawer > Settings > Network & internet > Ethernet** to check the connectivity;

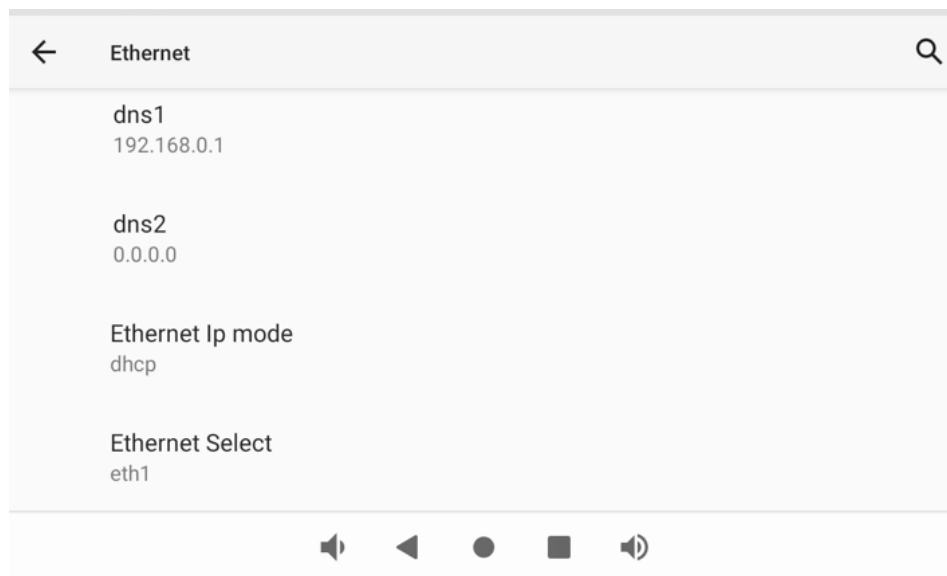

i Information of the **eth0** interface is displayed by default, so you may need to change the network interface to **eth1** via the **Ethernet Select** option at the bottom if you have just plugged the Ethernet cable into eth1.

3. You can click on the Ethernet IP mode option to manually assign an IP of the same network segment to the board. Remember to click **CONNECT** before exit.

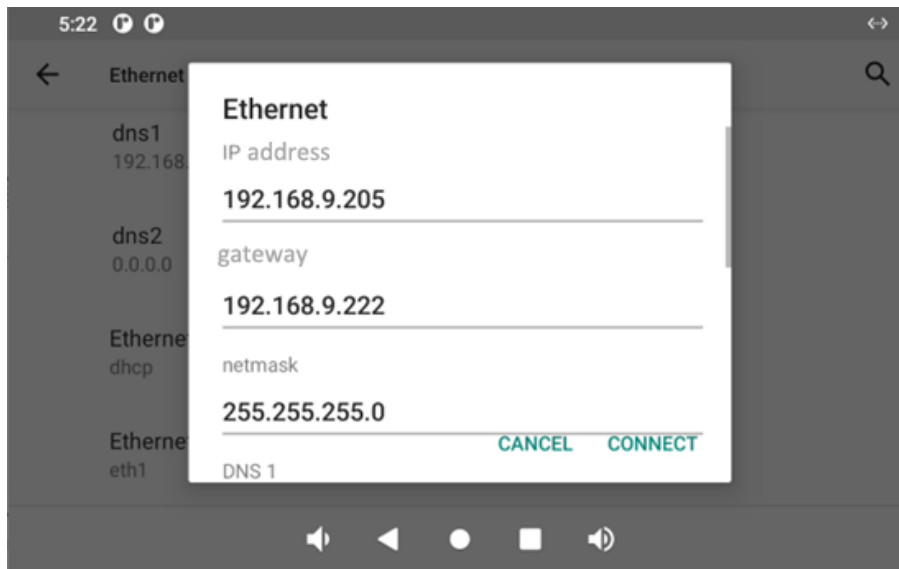

3.4.2 Wi-Fi

Before joining a Wi-Fi hotspot, please install the Wi-Fi antenna to the antenna connector on the board for improved signal strength.

When connecting to a Wi-Fi network, navigate to **Settings > Network & internet > Wi-Fi** to enable Wi-Fi feature. Then select and join the desired access point.

3.4.3 Cellular

VT-SBC-3568-GEN2 supports connecting a 4G/5G module via the M.2 B-Key slot for cellular communication. If you select the module provided by Vantron, it comes with a pre-configured script that automatically sets up the system upon bootup. When an activated SIM card is inserted into the Nano SIM slot, the system will automatically register the card and establish an internet connection.

3.5 Peripheral I/Os

3.5.1 RS232/RS485

VT-SBC-3568-GEN2 implements three RS232/RS485 multiplexers. J103 is named as UART0 and seated away from the other two headers, J102 (UART4) and J101 (UART6). They are mapped as `/dev/ttyS0`, `/dev/ttyS4`, and `/dev/ttyS6`, respectively in the software file system. The pinout of each multiplexer is described in 2.4.13.

The multiplexers are configured to operate in RS232 mode by default. You can set the serial parameters, such as the baud rate, based on needs.

Take J102 (UART4) as an example to test if it functions properly:

1. Properly wire the pins (RS232: TX-RX, RX-TX, GND-GND / RS485: A-A, B-B, GND-GND);
2. Connect VT-SBC-3568-GEN2 to a host computer through the USB Type-C port using a USB Type-A to Type-C cable (or through the debug UART based on the pinout set out in 2.4.14);
3. Open a terminal on the host computer and use the following command to access the board's shell;

```
$ adb shell
```

4. Switch to the root privilege;

```
$ su
```

5. Open the port using the command as follows (the baud rate is customizable);

```
microcom -s 9600 /dev/ttyS4
```

6. Open another terminal and input data to test the data receiving and transmission.

The multiplexers are configured to operate **in RS232 mode by default**. You can switch the work mode of the ports using the commands as follows. Please mind the pin wiring when switching the modes.

To switch from the RS232 mode to the RS485 mode:

```
echo 0 > sys/van-misc/RS485232_1_sel_pin // for dev/ttyS4
echo 0 > sys/van-misc/RS485232_2_sel_pin // for dev/ttyS6
echo 0 > sys/van-misc/RS485232_3_sel_pin // for dev/ttyS0
```

To switch from the RS485 mode to the RS232 mode:

```
echo 0 > sys/van-misc/RS485232_1_sel_pin // for dev/ttyS4
echo 0 > sys/van-misc/RS485232_2_sel_pin // for dev/ttyS6
echo 0 > sys/van-misc/RS485232_3_sel_pin // for dev/ttyS0
```

After switching the mode, use the following command to open the port:

```
# microcom -s 9600 /dev/ttySx
```

3.5.2 UART

VT-SBC-3568-GEN2 offers two UART headers. UART2 (J33) is for debugging the board, and UART9 (J32) is for serial communication. They are mapped as /dev/ttyS2 and /dev/ttyS9, respectively in the software file system. The pinout of the headers is described in 2.4.14.

To test the serial communication port UART9 (/dev/ttyS9), follow the steps below:

1. Wire the pins of the port (TX-RX, RX-TX, GND-GND);
2. Connect VT-SBC-3568-GEN2 to a host computer through the USB Type-C port using a USB Type-A to Type-C cable (or through the debug UART based on the pinout set out in 2.4.14);
3. Open a terminal on the host computer and use the following command to access the board's shell;

```
$ adb shell
```

4. Switch to the root privilege;

```
$ su
```

5. Open the port using the command as follows (the baud rate is customizable);

```
microcom -s 9600 /dev/ttyS9
```

6. Open another terminal and input data to test the data receiving and transmission.

3.5.3 CAN

VT-SBC-3568-GEN2 implements two CAN buses (CAN0 & CAN1). Refer to 2.4.15 for the pinout description.

Take **CAN0** as an example to test if it functions properly:

1. Connect CAN0 to a CAN analyzer (H-H, L-L, GND-GND);
2. Connect VT-SBC-3568-GEN2 to a host computer through the USB Type-C port using a USB Type-A to Type-C cable (or through the debug UART based on the pinout set out in 2.4.14);
3. Open a terminal on the host computer and use the following command to access the board's shell;

```
$ adb shell
```

4. Switch to the root privilege;

```
$ su
```

5. Check the network interface information of the board, and confirm if the CAN0 interface exists;

```
# ifconfig
```

6. Enable CAN0 and set the bitrate (such as 125000);

```
# ip link set can0 up type can bitrate 125000
```

7. Receive data sent to this port;

```
# candump can0
```

8. Transmit data from this port.

```
# cansend can0 123#1DEADBEEF
```

3.5.4 GPIO

VT-SBC-3568-GEN2 offers up to 18 GPIOs with pinout described in 2.4.16. GPIO1 ~ GPIO18 are mapped as gpio1 ~ gpio18 in the file system, respectively.

Take GPIO1 for example, to test if it functions properly:

```
echo 1 > sys/gpiox-ctl/gpio1_out // pull up  
echo 0 > sys/gpiox-ctl/gpio1_out // pull down
```

3.6 Firmware Upgrade in Windows Environment

1. Follow the steps in 3.2 to finish ADB setup on the Windows host computer;
2. Unzip the release package and open the directory of the upgrade driver (\SW \DriverAssitant_vxxx);
3. Right click the mouse and run the driver program **DriverInstall.exe** as administrator;
4. Click **Install Driver** and wait for the installation to proceed;

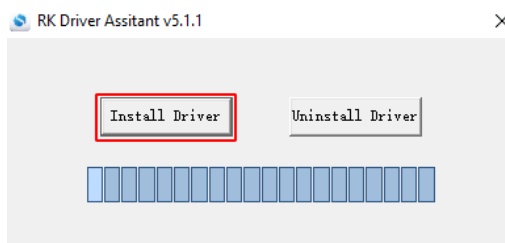

5. A pop-up will appear in a second suggesting the driver is installed;

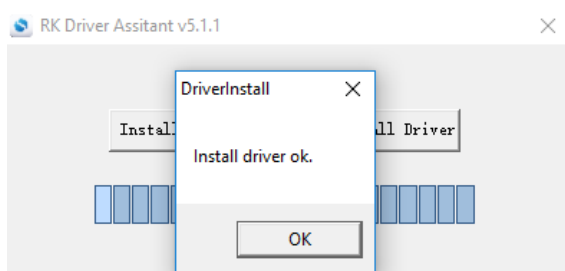

6. Open the directory of the upgrade tool (\SW\AndroidTool\RKDevTool_Release_vxxx);
7. Double click the driver for the upgrade tool **RKDevTool.exe** to open the upgrade window;

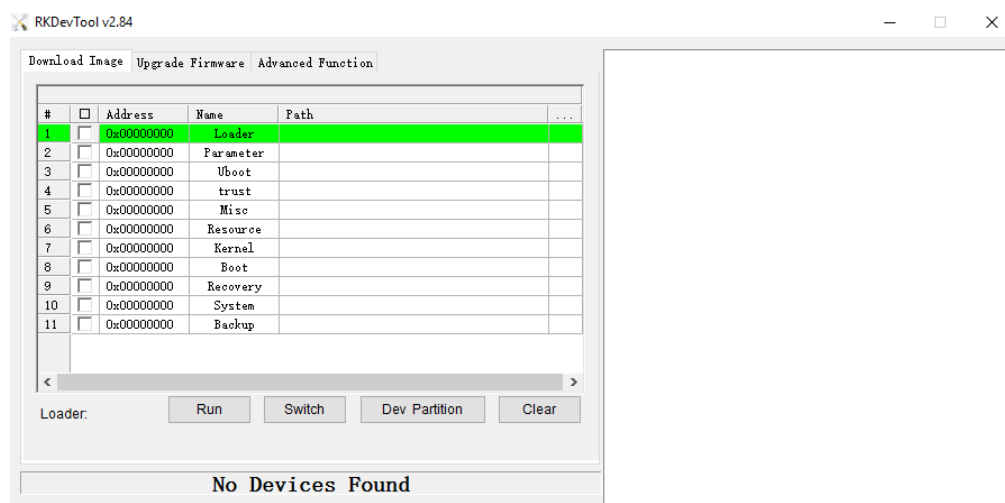

8. Connect VT-SBC-3568-GEN2 to the Windows host with the USB Type-A to Type-C cable;

9. Press “Win + R” and input `cmd` in the dialog box to open the command prompt;
10. Input `adb devices` in the command prompt to check if the board is connected to the Windows host;
11. Once the board is identified by the Windows host, input `adb reboot loader` to reboot the board into the bootloader mode;
12. Then the upgrade window will prompt for the existence of a Loader device, indicating that the upgrade process is ready;

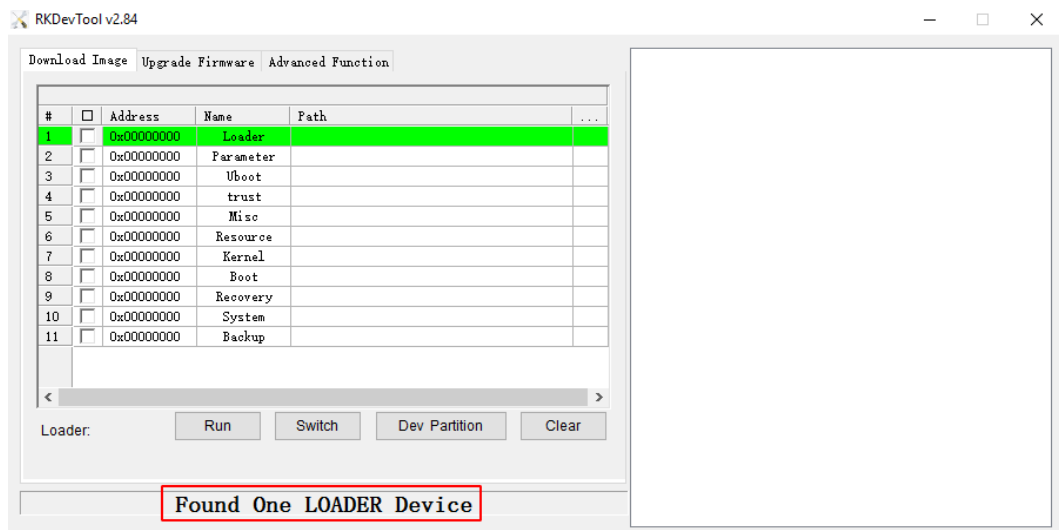

13. Click **Upgrade Firmware > Firmware** in the upgrade window;
14. Select the upgrade file (**update.img**) from the directory (`\\SW\Image`) and click **Open**, and the firmware details will be automatically populated in the boxes;
15. Click the **Upgrade** button and the Board will start to download the image and upgrade the firmware automatically;

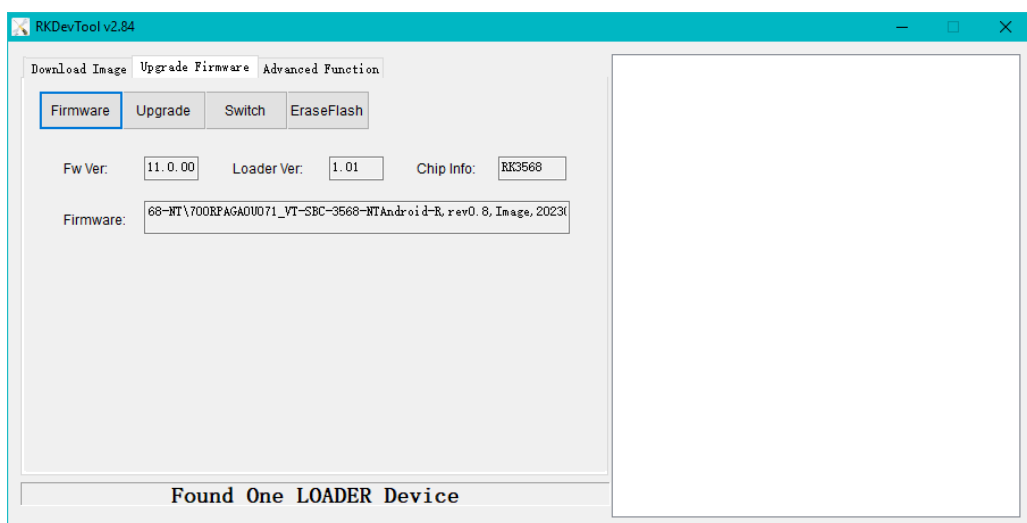

16. When the upgrade finishes, the Board will reboot automatically.

3.7 Firmware Upgrade in Ubuntu Environment

1. Connect VT-SBC-3568-GEN2 to the Ubuntu host using the USB Type-A to Type-C cable;
2. Open a terminal and input the following command to install the ADB tool if necessary;

```
$ sudo apt-get install adb -y
```

3. Check if the board is connected to the Ubuntu host computer via the ADB tool;

```
$ adb devices -l
```

4. Execute `adb shell` to access the board's shell;
5. Run `reboot loader` to reboot the board to the bootloader mode;

```
root@ubuntu:~$ adb shell
root@linaro-alip:/# reboot loader
root@linaro-alip:/# root@ubuntu:~$
```

6. Copy the release package to the Ubuntu system or save the release package to a USB drive and mount the USB drive to the Ubuntu system;
7. Open the directory of the upgrade tool (named as "upgrade_tool" in the package) in the system (\SW\Linux_Upgrade_Tool_vxxx) and unzip the folder;
8. Right click the mouse in an empty space of the folder and click **Open in Terminal**;
9. Input the following command to start the upgrade process;

```
$ sudo ./upgrade_tool uf xxx/update.img
```

-  *"xxx" is the path of the image file (update.img), usually found in /SW/Image.*
10. The system will start upgrading after the download finishes, and it will reboot automatically when the upgrade finishes.

CHAPTER 4 DEBIAN SYTEM MANUAL

VT-SBC-3568-GEN2 is running Debian 11 operating system. To properly test the functionality of the board described in this chapter, you are advised to connect the board to a mouse, keyboard, and monitor for easier operations.

4.1 About the Device

Upon startup, the board will automatically log in without requiring the input of the password. However, the password for the default user “linaro” is “linaro” in case you need to switch users or create a new user. If you need to switch to the root user for higher privilege in the device terminal, simply use the `sudo su` command without the need to enter a password.

4.1.1 Device information

1. Power on the board and the system will log in to linaro as the default user;
2. Right click the mouse in an empty area to open the property dialogue of the board;
3. Click **Applications > About Xface** to enter the desktop environment, then you can check the system information like device name, operating system, copyright statement, etc.

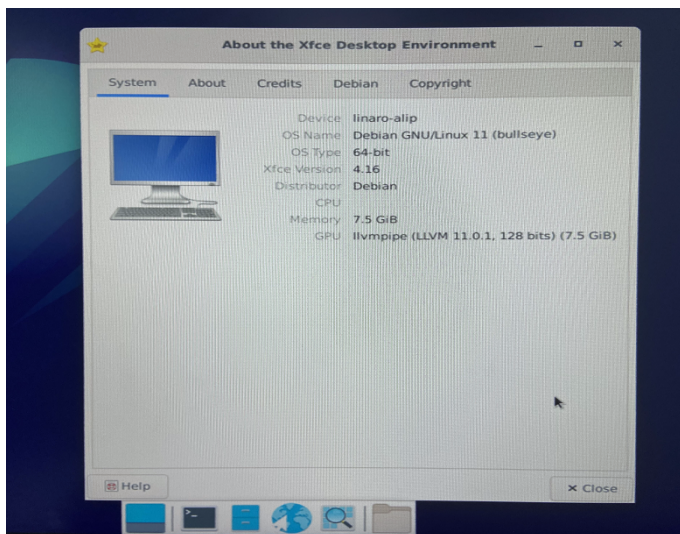

You can also execute commands to check the device information.

1. Press `Ctrl + Alt + T` simultaneously or click the **LXTerminal** () tool from the taskbar at the bottom of the screen to open a terminal;
2. Switch to the root user using the command `sudo su`;
3. Check the software version:

```
# cat /etc/versions
```

4. Check the kernel information:

```
# uname -a
```

4.1.2 System settings

By clicking on **linaro** on the top right corner of the screen, you can

- Lock the screen;
- Switch the user;
- Shut down/suspend the board;
- (Upon a click of the “Log out” option) Log out/restart/shut down/suspend the board or switch the user while saving the session for future logins.

The menu bar on the top of the screen allows the user to:

- Change the brightness and power settings of the board;
- Adjust the system volume and sound settings;
- Add the board to a Wi-Fi or Ethernet or mobile network and pair it with a Bluetooth device;
- Switch between different workspaces.

Other system settings are accessible from **Applications** on the top left corner of the screen or upon a right click of the mouse in an empty area of the screen.

4.1.3 EEPROM

EEPROM is a non-volatile memory that retains stored data even when the power is turned off. The device information is stored in the EEPROM.

1. Locate the EEPROM file:

```
# find /sys/devices -name "*eeprom*"
/sys/devices/platform/fdd40000.i2c/i2c-0/0-0050/eeprom
```

2. Set a software link for the EEPROM device for easy access:

```
# ln -s /sys/devices/platform/fdd40000.i2c/i2c-0/0-0050/eeprom /dev/eeprom
```

3. Clear the EEPROM information:

```
# vtvdn -i
```

4. Read the serial number of the board written in EEPROM:

```
# vtvdn -r sn
xxxx
```

4.1.4 RTC

Real-Time Clock (RTC) is a hardware component on the board that keeps track of the device time and date. Adjusting the RTC can help address issues related to time discrepancies or resets in software system time settings. To modify the time zone, date, or time, open a terminal and execute the following commands.

1. Execute the following command to enter time zone selection;

```
$ tzselect
```

2. Select the desire time zone and geographic region according to the on-screen prompt (e.g., Detroit, America);

3. Copy the time zone file to the local time directory (/etc/localtime);

```
$ sudo cp /usr/share/zoneinfo/America/Detroit /etc/localtime
```

4. Write the system time zone information to the hardware;

```
# hwclock --systohc
```

5. Check the current time zone information:

```
# cat /etc/timezone
```

6. Set the system date & time;

```
# date -s "Aug-04-2024 14:38:10" // replace with your own date and time
```

7. Synchronize the RTC time with the system time;

```
# hwclock -w
```

8. Reboot the device;

```
# reboot
```

9. Check the RTC time information.

```
# hwclock -r
```

4.2 Network Connectivity

4.2.1 Ethernet

After connecting VT-SBC-3568-GEN2 to a router or switch through either of the Ethernet jacks, you can use the GUI to configure the Ethernet network upon clicking the network icon () on the taskbar in the upper right corner of the screen.

Alternatively, you can use the terminal to check the network information as shown below.

1. Open a terminal by pressing Ctrl + Alt + T;
2. Use the `ifconfig` command to check the information of the network interfaces:

```
# ifconfig
eth0: flags=4163<UP,BROADCAST,RUNNING,MULTICAST> mtu 1500
    inet 192.168.19.208 netmask 255.255.255.0 broadcast 192.168.19.255
    inet6 fe80::239b:dba1:dc0f:5535 prefixlen 64 scopeid 0x20<link>
    ether 12:34:24:00:9a:bc txqueuelen 1000 (Ethernet)
    RX packets 2384 bytes 219409 (214.2 KiB)
    RX errors 0 dropped 961 overruns 0 frame 0
    TX packets 122 bytes 9667 (9.4 KiB)
    TX errors 0 dropped 0 overruns 0 carrier 0 collisions 0
    device interrupt 70



eth1: flags=4163<UP,BROADCAST,RUNNING,MULTICAST> mtu 1500
    inet 192.168.19.202 netmask 255.255.255.0 broadcast 192.168.19.255
    inet6 fe80::cc9f:7dd0:bc71:bc1d prefixlen 64 scopeid 0x20<link>
    ether 12:88:66:00:9a:bc txqueuelen 1000 (Ethernet)
    RX packets 224 bytes 2312 (2.2 KiB)
    RX errors 0 dropped 0 overruns 0 frame 0
    TX packets 17 bytes 2872 (2.8 KiB)
    TX errors 0 dropped 0 overruns 0 carrier 0 collisions 0
    device interrupt 73
```

3. Assign a static IP address of the same network segment to an Ethernet jack (e.g., eth0) and test the connectivity:



```
# ifconfig eth0 192.168.19.10
# ping 192.168.19.10
PING 192.168.19.10 (192.168.19.10): 56 data bytes
64 bytes from 192.168.19.10: seq=0 ttl=64 time=1.296 ms
64 bytes from 192.168.19.10: seq=1 ttl=64 time=1.358 ms
```

4.2.2 Wi-Fi

Before connecting to a Wi-Fi network, please install the Wi-Fi antennas to J10 and J12 connectors for better signal strength. Use the GUI to connect to a Wi-Fi hotspot.

1. Click the network icon () on the taskbar in the upper right corner of the screen;
2. Select the desired SSID from the available list;
3. Click the **More networks** option to expand the list, if needed;
4. Enter the password for the network;
5. Once the device is connected to the target network, a “**Connection Established**” prompt will be displayed, indicating the name of the network you are connected to, and the network icon will change to a wireless network icon ();
6. You can click **Disconnect** below the SSID to disconnect the device from the network.

4.2.3 Pairing with a Bluetooth device

1. Click the Bluetooth icon () on the taskbar in the bottom right corner of the screen;
2. Select the **Turn Bluetooth On** option;
3. Click the Bluetooth on icon () and select the **Set Up New Device** option;
4. In the Bluetooth device setup window, Click **Next** and the available Bluetooth devices will be displayed;
5. Navigate through the list to locate the desired Bluetooth device, select it and click **Next**;
6. Select **Pair Device** as the pairing method and click **Next**;
7. Confirm the pair code on both devices;
8. In the final step, there will be a message indicating that the target device is successfully added and connected;
9. The Bluetooth icon on the taskbar will change accordingly ().

4.2.4 Sending a file to a Bluetooth device

1. Tap on the Bluetooth icon () and select the **Send Files to Device** option;
2. Select the file you intend to send and tap on **OK**;
3. Select the target device from the device list and tap on **OK**;
4. If the two devices are connected, the file transfer will be initiated immediately. Otherwise, the transfer may fail, and you'll need pair the devices before proceeding;
5. Wait for the file to be transferred.

4.2.5 Cellular

VT-SBC-3568-GEN2 supports connecting a 4G/5G module via the M.2 B-Key slot for cellular communication.

For the FM150-AE module, you can use the following commands for internet access.

1. Insert the cellular module and power on the board, then check the module information:

```
# ls /dev/ttyUSB*
```

2. Execute the following command to access internet:

```
# echo -e \"AT+GTRNDIS=1,1\\r\" > /dev/ttyUSB2
```

3. Use the `ping` command to check the network connectivity.

```
root@linaro-alip:/home/linaro# echo -e \"AT+GTRNDIS=1,1\\r\" > /dev/ttyUSB2
root@linaro-alip:/home/linaro# ping -I enxfe7eccca05275 8.8.8.8
PING 8.8.8.8 (8.8.8.8) from 192.168.225.53 enxfe7eccca05275: 56(84) bytes of data.
64 bytes from 8.8.8.8: icmp_seq=1 ttl=50 time=215 ms
64 bytes from 8.8.8.8: icmp_seq=2 ttl=50 time=88.8 ms
64 bytes from 8.8.8.8: icmp_seq=3 ttl=50 time=127 ms
64 bytes from 8.8.8.8: icmp_seq=4 ttl=50 time=87.3 ms
64 bytes from 8.8.8.8: icmp_seq=5 ttl=50 time=124 ms
```

4.3 Peripheral I/Os

This section focuses on the first-use debugging of the interfaces or programs. You are advised to use a mouse, keyboard, and monitor to connect VT-SBC-3568-GEN2 and test directly in the board's console.

Alternatively, you can connect VT-SBC-3568-GEN2 to a host computer using a USB Type-A to USB Type-C cable through the USB Type-C port or through the debug UART using a USB to UART (3.3V) adapter based on the pinout set out in 2.4.14.

4.3.1 USB

Insert a USB device into any of the USB interfaces on the board, and input the following commands to check/configure the USB device.

1. Check the information of all connected USB devices:

```
$ lsusb
```

2. Display the details of the hard disks and their partitions:

```
$ fdisk -l
```

3. Mount a USB drive to a specified directory (e.g., /mnt):

```
$ mount /dev/xxx /mnt
```

4. Check the mounted content:

```
$ ls /mnt
```

5. Unmount the USB drive:

```
$ umount /dev/xxx
```

4.3.2 RS232/RS422/RS485

VT-SBC-3568-GEN2 implements three RS232/RS485 multiplexers. J103 is named as UART0 and seated away from the other two headers, J102 (UART4) and J101 (UART6). They are mapped as /dev/ttyS0, /dev/ttyS4, and /dev/ttyS6, respectively in the software file system. The pinout of each multiplexer is described in 2.4.13.

The multiplexers are configured to **operate in RS232 mode by default**. You can set the serial parameters, such as the baud rate, based on needs.

Before testing:

1. Properly wire the pins (RS232: TX-RX, RX-TX, GND-GND / RS485: A-A, B-B, GND-GND);
2. Use the mouse, keyboard, and monitor to connect the board;
3. Open a terminal, and use the `sudo su` command to switch to the root privilege.

Follow the commands listed below to test the functionality of the ports:

RS232 mode:

UART0

```
# echo 40 > /sys/class/gpio/export           // export the pin
# echo out > /sys/class/gpio/gpio118/direction // set the pin's direction as output
# echo 0 > /sys/class/gpio/gpio40/value      // set the pin's output to low
# minicom -D /dev/ttyS0 -b 115200           // open the port (with flow control disabled)
```

UART4

```
# echo 118 > /sys/class/gpio/export          // export the pin
# echo out > /sys/class/gpio/gpio118/direction // set the pin's direction as output
# echo 0 > /sys/class/gpio/gpio118/value     // set the pin's output to low
# minicom -D /dev/ttyS4 -b 115200           // open the port (with flow control disabled)
```

UART6

```
# echo 119 > /sys/class/gpio/export          // export the pin
# echo out > /sys/class/gpio/gpio119/direction // set the pin's direction as output
# echo 0 > /sys/class/gpio/gpio119/value     // set the pin's output to low
# minicom -D /dev/ttyS6 -b 115200           // open the port (with flow control disabled)
```

RS485 mode:

UART0

```
# echo 40 > /sys/class/gpio/export // export the pin
# echo out > /sys/class/gpio/gpio40/direction // set the pin's direction as output
# echo 1 > /sys/class/gpio/gpio40/value // set the pin's output to high
# minicom -D /dev/ttyS0 -b 115200 // open the port (with flow control disabled)
```

UART4

```
# echo 118 > /sys/class/gpio/export // export the pin
# echo out > /sys/class/gpio/gpio118/direction // set the pin's direction as output
# echo 1 > /sys/class/gpio/gpio118/value // set the pin's output to high
# minicom -D /dev/ttyS4 -b 115200 // open the port (with flow control disabled)
```

UART6

```
# echo 119 > /sys/class/gpio/export // export the pin
# echo out > /sys/class/gpio/gpio119/direction // set the pin's direction as output
# echo 1 > /sys/class/gpio/gpio119/value // set the pin's output to high
# minicom -D /dev/ttyS6 -b 115200 // open the port (with flow control disabled)
```

4.3.3 UART

VT-SBC-3568-GEN2 offers two UART headers. UART2 (J33) is for debugging the board, and UART9 (J32) is for serial communication. They are mapped as /dev/ttyS2 and /dev/ttyS9, respectively in the software file system. The pinout of the headers is described in 2.4.14.

To test the serial communication port UART9 (/dev/ttyS9), follow the steps below:

1. Properly wire the pins (RS232: TX-RX, RX-TX, GND-GND / RS485: A-A, B-B, GND-GND);
2. Use the mouse, keyboard, and monitor to connect the board, and open a terminal;
3. Use the `sudo su` command to switch to the root privilege;
4. Set the baud rate (such as 115,200);

```
# stty -F /dev/ttyS9 speed 115200
```

5. Receive data sent to this port:

```
# cat /dev/ttyS9
```

6. Send data from this port:

```
# echo abcd > /dev/ttyS9
```

4.3.4 CAN

VT-SBC-3568-GEN2 implements two CAN buses (CAN0 & CAN1). Refer to 2.4.15 for the pinout description.

Take **CAN0** as an example to test if it functions properly:

1. Connect CAN0 to a CAN analyzer (H-H, L-L, GND-GND);
2. Use the mouse, keyboard, and monitor to connect the board;
3. Open a terminal, and use the `sudo su` command to switch to the root privilege;
4. Check the network interface information of the board, and confirm if the CAN0 interface exists;

```
# ifconfig
```

5. Disable CAN0;

```
# ip link set can0 down
```

6. Set the bitrate of CAN0 to 500,000;

```
# ip link set can0 type can bitrate 500000
```

7. Enable CAN0;

```
# ip link set can0 up
```

8. Receive the data sent to the port;

```
# candump can0
```

9. Send data from this port.

```
# cansend can0 123#1DEADBEEF
```

4.3.5 GPIO

By executing the GPIO test script (`gpio_test.sh`), the pins will be pulled up and down repeatedly. Users can use a multimeter to measure the voltage on the pins to verify their state.

```
# chmod +x gpio_test.sh // Add executable permission
```

```
# ./gpio_test.sh // Run the script
```

4.3.6 Audio

When testing the board's audio function, please connect an audio cable that supports audio recording and playback to the 3.5mm audio jack or connect a microphone to the D-Mic/A-Mic connector.

1. Use the microphone on the audio cable to record an audio clip and name it as test.wav:

```
$ arecord -D hw:0,0 --period-size=1024 --buffer-size=4096 -r 48000 -c 2 -f s16_le test.wav // hw is followed by the audio device
```

2. Play back the recorded audio clip:

```
$ play -D hw:0,0 --period-size=1024 --buffer-size=4096 -r 48000 -c 2 -f s16_le test.wav
```

3. Record audio and play it back in real-time:

```
$ arecord -D hw:0,0 --period-size=1024 --buffer-size=4096 -r 48000 -c 2 -f s16_le -t raw | aplay -D hw:0,0 --period-size=1024 --buffer-size=4096 -r 48000 -c 2 -f s16_le -t raw
```

4. You can press Ctrl + C to stop recording or playing back the audio clip.

Play back the audio via the HDMI port:

1. Use an HDMI cable to connect the board and the audio receiving device;
2. Use the following command to play back the audio clip.

```
$ aplay -D hw:1,0 test.wav // hw is followed by the audio device
```

4.3.7 Video

When testing the video output function of the HDMI port on the board, please connect a video receiving device to the port using an HDMI cable.

Use the following command to play back

```
$ gst-play-1.0 1920x1080.mp4 // name of the video clip
```

4.3.8 Camera

When testing the function of the MIPI CSI interface, please use the FPC/FFP flexible cable to connect the MIPI CSI interface to the camera. You can refer to 2.4.8 for the pinout description of the MIPI CSI interface.

Use the following command to preview the photos collected:

```
$ gst-launch-1.0 v4l2src device=/dev/video0 ! video/x-raw,width=1920,height=1080,framerate=30/1 ! autovideosink
```

CHAPTER 5 DISPOSAL AND PRODUCT WARRANTY

5.1 Disposal

When the device comes to end of life, you are suggested to properly dispose of the device for the sake of the environment and safety.

Before you dispose of the device, please back up your data and erase it from the device.

It is recommended that the device is disassembled prior to disposal in conformity with local regulations. Please ensure that the abandoned batteries are disposed of according to local regulations on waste disposal. Do not throw batteries into fire or put in common waste canister as they are explosive. Products or product packages labeled with the sign of “explosive” should not be disposed of like household waste but delivered to specialized electrical & electronic waste recycling/disposal center.

Proper disposal of this sort of waste helps avoid harm and adverse effect upon surroundings and people’s health. Please contact local organizations or recycling/disposal center for more recycling/disposal methods of related products.

5.2 Warranty

Product warranty

VANTRON warrants to its CUSTOMER that the Product manufactured by VANTRON, or its subcontractors will conform strictly to the mutually agreed specifications and be free from defects in workmanship and materials (except that which is furnished by the CUSTOMER) upon shipment from VANTRON. VANTRON's obligation under this warranty is limited to replacing or repairing at its option of the Product which shall, within **24 months** after shipment, effective from invoice date, be returned to VANTRON's factory with transportation fee paid by the CUSTOMER and which shall, after examination, be disclosed to VANTRON's reasonable satisfaction to be thus defective. VANTRON shall bear the transportation fee for the shipment of the Product to the CUSTOMER.

Out-of-Warranty Repair

VANTRON will furnish the repair services for the Product which are out-of-warranty at VANTRON's then-prevailing rates for such services. At customer's request, VANTRON will provide components to the CUSTOMER for non-warranty repair. VANTRON will provide this service as long as the components are available in the market; and the CUSTOMER is requested to place a purchase order up front. Parts repaired will have an extended warranty of 3 months.

Returned Products

Any Product found to be defective and covered under warranty pursuant to Clause above, shall be returned to VANTRON only upon the CUSTOMER's receipt of and with reference to a VANTRON supplied Returned Materials Authorization (RMA) number. VANTRON shall supply a RMA, when required within three (3) working days of request by the CUSTOMER. VANTRON shall submit a new invoice to the CUSTOMER upon shipping of the returned products to the CUSTOMER. Prior to the return of any products by the CUSTOMER due to rejection or warranty defect, the CUSTOMER shall afford VANTRON the opportunity to inspect such products at the CUSTOMER's location and no Product so inspected shall be returned to VANTRON unless the cause for the rejection or defect is determined to be the responsibility of VANTRON. VANTRON shall in turn provide the CUSTOMER turnaround shipment on defective Product within **fourteen (14) working days** upon its receipt at VANTRON. If such turnaround cannot be provided by VANTRON due to causes beyond the control of VANTRON, VANTRON shall document such instances and notify the CUSTOMER immediately.