

VOSM93 System-on-Module

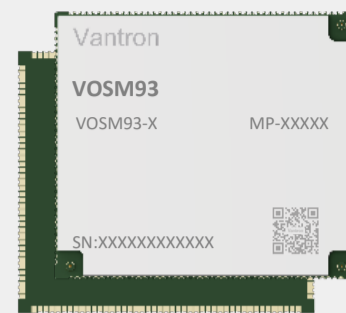

Product Brief

VOSM93 system-on-module is powered by NXP i.MX9352 processor with main frequency up to 1.7GHz. The module integrates a dual-core Arm Cortex-A55 processor, an Arm Cortex-M33 co-processor running up to 250 MHz for real-time and low-power processing, and an NPU for machine learning acceleration. It offers 2GB LPDDR4x on-chip memory and 16GB eMMC 5.1 storage. The Wi-Fi and Bluetooth module is ready for use, and it also offers a Gigabit Ethernet controller to drive gateway applications with low latency. In addition, the module boasts rich peripheral interfaces, including USB 2.0, I²C, CAN, SPI, UART, and GPIO to increase its versatility for diverse scenarios, particularly in industrial HMI, industrial vision, EV charging, industrial automation, and more.

The module features an LGA packaging that allows for direct welding, eliminating the need for additional connectors. It is compliant with Open Standard Modules (OSM) V1.1, which enables seamless integration into various products. Moreover, the module provides an extended service life that meets the rigorous demands of industrial customers.

Features and benefits

VOSM93	
	Efficient machine learning acceleration
	Rich interfaces, robust system performance
	Wi-Fi 5 & Bluetooth 5.0
	Linux Yocto operating system
	Compact size, LGA packaging
	Open Standard Modules (OSM) V1.1 compliant
	Extended service life (7+ years)

Application Scenarios



Industrial HMI



EV Charging



Energy Meter



Smart Home



Machine Vision



Smart Retail

VOSM93 System-on-Module Datasheet

Specification		
System	CPU	NXP i.MX 9352, Dual-core ARM Cortex-A55 processor, up to 1.7GHz ARM Cortex-M33 low-power real-time co-processor, 250MHz
	Micro NPU	0.5 TOPS
	Memory	2GB LPDDR4
	Storage	16GB eMMC 5.1
	EEPROM	2Kb (for hardware configuration information)
Communication	Wi-Fi & Bluetooth	Wi-Fi 802.11 a/b/g/n/ac + Bluetooth 5.0
	Ethernet	Gigabit Ethernet controller
Media	Pixel Format	Multiple pixel format support (YUV444, YUV422, YUV420, YUV400)
	Image Processing	Pixel rate up to 200 Mpixel/s
	Audio Processing	Medium Quality Sound (MQS) output
Power	Input	5V/2A DC input
Software	Operating System	Linux Yocto
Mechanical	Dimensions	45mm x 45mm
Environment Condition	Temperature	Operating: 0°C ~ +60°C (Optional: -40°C ~ +85°C) Storage: -20°C ~ +70°C
	Humidity	≤95% RH (Non-condensing)

I/O		
Display	1 x 4-lane MIPI DSI, up to 1080P @60Hz	1 x 4-lane LVDS, up to 720P @60Hz
Camera	1 x 2-lane MIPI CSI-2, 1080p @30Hz	
Audio	2 x I ² S	
Ethernet	1 x RGMII	
USB	2 x USB 2.0 OTG	
SDIO	1 x 4-bit SDIO V3.0	
ADC	1 x ADC input	
SPI	1 x SPI	
UART	3 x Communication UART (TTL)	1 x Debug UART (1.8V level)
CAN	2 x CAN	
I ² C	2 x I ² C	
GPIO	13 x GPIO (Max.)	
JTAG	Supported	
Key	1 x Power key	1 x Reset key
PWM	2 x PWM	

Electrical Characteristics

Absolute Maximum Ratings

Voltage beyond absolute maximum ratings may cause permanent damage to the module. Operation of the module outside of recommended conditions may result in reduced lifetime and/or reliability problems even if the absolute maximum ratings are not exceeded.

Parameter	Min.	Max.	Unit	
Voltage of the SOM	-0.5	6	V	
Voltage on Wi-Fi/BT chip	VBAT	-0.5	3.9	V
	VDDIO	-0.5	5	V
Voltage of LPDDR4	LPDDR4X VDD1	-0.4	2.1	V
	LPDDR4X VDD2	-0.4	1.5	V
	LPDDR4X VDDQ	-0.4	1.5	V
Storage temperature	-20	70	°C	

Recommended Operating Conditions

You are recommended to operate the module in the following conditions to achieve optimized performance of the module.

Parameter	Min.	Typ.	Max.	Unit	
Voltage of the SOM	2.7	4.4	5.5	V	
Voltage on Wi-Fi/BT chip	VBAT	3	3.3	4.4	V
	VDDIO	1.6	1.8	3.6	V
VDD_SOC	0.8	0.85	0.9	V	
VDD_ANA_0P8	0.76	0.8	0.84	V	
VDD_MIPI_0P8	0.76	0.8	0.84	V	
VDD_USB_0P8	0.76	0.8	0.84	V	
VDD_ANAx_1P8	1.71	1.8	1.89	V	
VDD_LVDS_1P8	1.71	1.8	1.89	V	
VDD_MIPI_1P8	1.71	1.8	1.89	V	
VDD_USB_1P8	1.71	1.8	1.89	V	
VDD_USB_3P3	3.069	3.3	3.45	V	

(To be continued...)

Recommended Operating Conditions (Cont'd)

Parameter	Min.	Typ.	Max.	Unit
VDD2_DDR	1.06	1.1	1.14	V
VDDQ_DDR	0.57	0.6	0.67	V
NVCC_BBSM_1P8	1.62	1.8	1.98	V
NVCC_AON	1.62	1.8	1.98	V
NVCC_SD2	1.62	1.8	1.98	V
NVCC_GPIO	1.62	1.8	1.98	V
NVCC_WAKEUP	1.62	1.8	1.98	V

Block Diagram

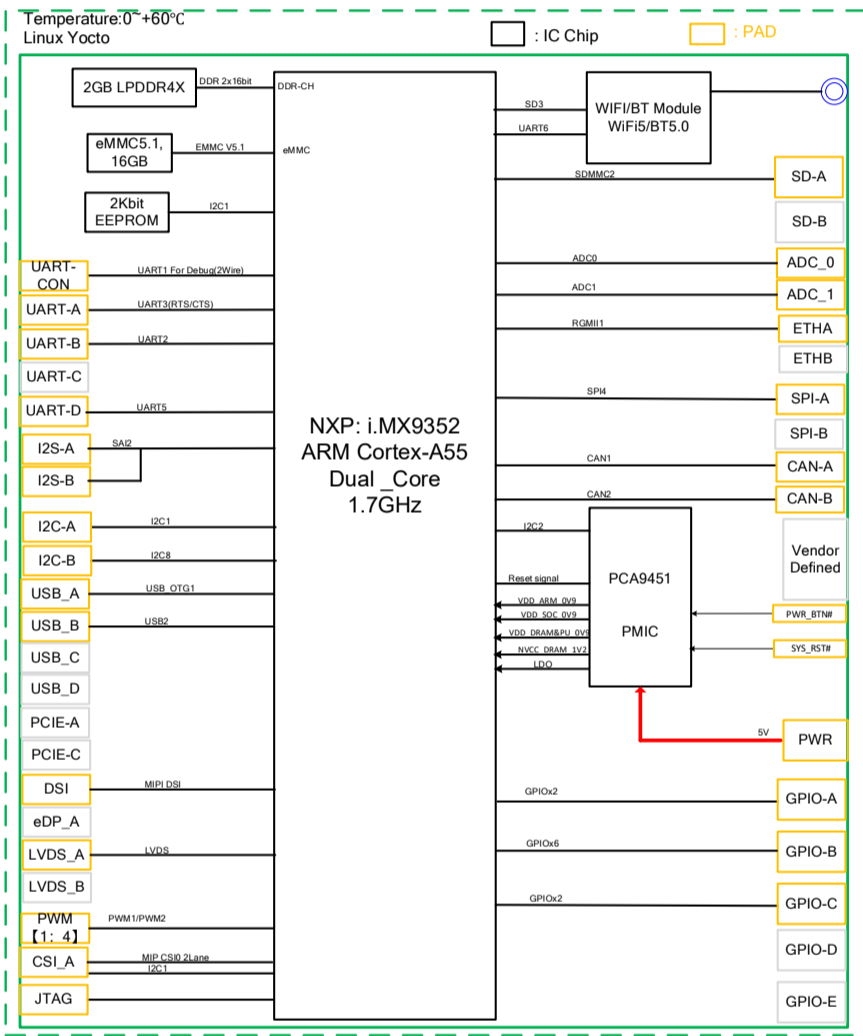

Pinout

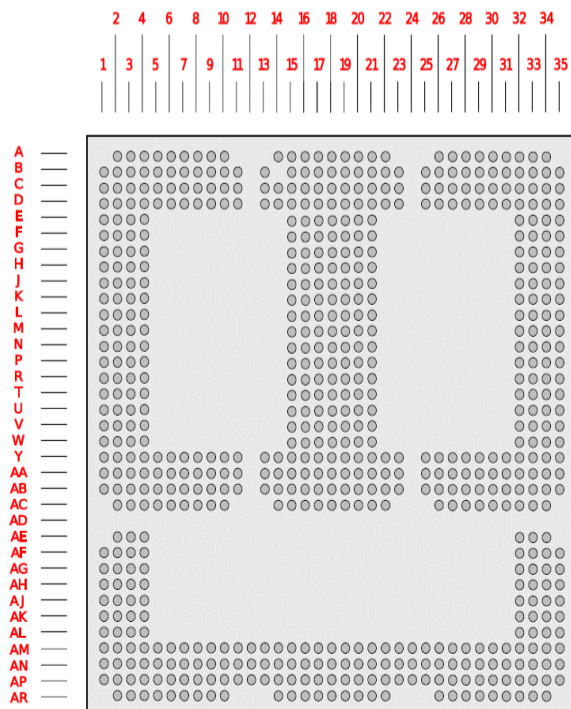

Pin	Signal*	CPU Pad Name*	Description
U19, R18, W17, M19	NC		No connection
V17	EXT_EN	GPIO_IO26	OSM module control signal
T17	BOOT_MODE1	UART2_TXD	System config. pin
AA9	ON/OFF	ONOFF	Power on/off (1.8V~5V*)
U17	NRST	PMIC_RST_B (PCA9451)	System reset input, active low
AB18	NC		No connection
AA18	NC		No connection
Y16, Y20, Y3, C5, AA33, B29	NC		No connection
Y17, Y8, Y9	NC		No connection
Y10, Y11, AE4, AF4, AG4, AH3	NC		No connection
Y25, Y26, Y27, Y28	VCC_IN_5V		5V power input
AH4, AJ3, AJ4, AK4, Y19, U18	NC		No connection
D18, E15, E21, F16, F20, J16	GND		Ground
J20, L18, M16, M20, P18, R16, R20	GND		Ground
V16, V20, Y18, AA14, AA17, AA19	GND		Ground
AA22, AB15, AB21, A4, A7, A10, B2, B5	GND		Ground
B8, B9, C11, D1, D5, D8, E2, H2, H4, L2	GND		Ground
L4, P2, P4, R1, U2, U4, V1, W3, Y2, AA1	GND		Ground
AA4, AA7, AA8, AA10, AA11, AB3	GND		Ground
AB6, AB9, AC4, AC7, AC10, A26, A29, A32	GND		Ground
B27, B28, B30, B33, C25, C32, C35, D28	GND		Ground
D34, F33, F35, G34, H32, J33, J35, K34	GND		Ground
M35, N34, T34, W34, AA25, AA26	GND		Ground
AA27, AA28, AA32, AB28, AB31, AB34	GND		Ground
AC27, AC30, AC33, AE34, AE2, AG3	GND		Ground

* Signal refers to the pin name used by Vantron.

* CPU Pad Name refers to corresponding pad name on the i.MX9352 CPU.

* Unless explicitly stated, the I/O level is 1.8V.

Pin	Signal	CPU Pad Name	Description
AH2, AK3, AL2, AF35, AH34	GND		Ground
AJ35, AL34, AM13, AM16, AM19	GND		Ground
AM22	GND		Ground
AM35, AN3, AN6, AN9, AP2, AN11	GND		Ground
AN15, AN18, AN21, AN33	GND		Ground
AP5, AP8, AP13, AP16	GND		Ground
AP19, AP22, AP25, AP28, AP31, AP34	GND		Ground
AR14, AR17, AR20, AR26, AR29, AR32	GND		Ground
AN30, AN31, AP10	NC		No connection
C2	MIPI_CSI_MCLK / GPIO	CCM_CLKO1	Camera clock output/GPIO
G3	MIPI_CSI_PWDN / GPIO	GPIO_IO28	Camera power down/GPIO
G4	MIPI_CSI_RST/GPIO	PDM_BIT_STREAM1	Camera interrupt signal input / GPIO
B3	CSI_CKN	MIPI_CSI1_CLK_N	Channel input CSI Clock N
B4	CSI_CKP	MIPI_CSI1_CLK_P	Channel input CSI Clock P
C1	CSIO_CO_LN0_M	MIPI_CSI1_D0_N	Channel input CSI lane 0 N
B1	CSIO_BO_LN0_P	MIPI_CSI1_D0_P	Channel input CSI lane 0 P
A2	CSI_L1N	MIPI_CSI1_D1_N	Channel input CSI lane 1 N
A3	CSI_L1P	MIPI_CSI1_D1_P	Channel input CSI lane 1 P
A5	CSI_L2N		No connection
A6	CSI_L2P		No connection
B6	CSI_L3N		No connection
B7	CSI_L3N		No connection
C4	I2C1_SCL_CAM	I2C1_SCL	I2C1 clock signal
C3	I2C1_SDA_CAM	I2C1_SDA	I2C1 data signal
F4	MIPI_DSI_BL_EN / GPIO	GPIO_IO11	MIPI_DSI 1V8 backlight enable signal output / GPIO
F3	MIPI_DSI_VDD_EN / GPIO	SAI1_TXFS	MIPI_DSI 3V3 power enable signal output / GPIO
E18	MIPI_DSI_PWM	GPIO_IO22	MIPI_DSI backlight PWM signal output
AB8	MIPI_TX_CLKN	MIPI_DSI1_CLK_N	MIPI_DSI differential clock lane -
AB7	MIPI_TX_CLKP	MIPI_DSI1_CLK_P	MIPI_DSI differential clock lane +
AB11	MIPI_TX_D0N	MIPI_DSI1_D0_N	MIPI_DSI differential lane 0 -

Pin	Signal	CPU Pad Name	Description
AB10	MIPI_TX_D0P	MIPI_DSI1_D0_P	MIPI_DSI differential lane 0 +
AC9	MIPI_TX_D1N	MIPI_DSI1_D1_N	MIPI_DSI differential lane 1 -
AC8	MIPI_TX_D1P	MIPI_DSI1_D1_P	MIPI_DSI differential lane 1 +
AC6	MIPI_TX_D2N	MIPI_DSI1_D2_N	MIPI_DSI differential lane 2 -
AC5	MIPI_TX_D2P	MIPI_DSI1_D2_P	MIPI_DSI differential lane 2 +
AB5	MIPI_TX_D3N	MIPI_DSI1_D3_N	MIPI_DSI differential lane 3 -
AB4	MIPI_TX_D3P	MIPI_DSI1_D3_P	MIPI_DSI differential lane 3 +
AA3	LCD_ID	GPIO_IO29	LCD_ID
V21	SAI2_RXD0	ENET2_TD1	I2S A Digital audio Input
W21	SAI2_TXD0	ENET2_RD3	I2S A Digital audio Output
V19	SAI2_RXD1	ENET2_TD0	I2S B Digital audio Input
W19	SAI2_TXD1	ENET2_RD2	I2S B Digital audio Output
W20	SAI2_BCLK	ENET2_TD2	I2S Digital audio clock
W18	SAI2_LRCLK	ENET2_TD3	I2S Left & Right synchronization clock
V18	SAI2_MCLK	ENET2_RD0	Master clock output to I2S codec(s)
AA15	I2C1_SCL	I2C1_SCL	I2C1_SCL
AA16	I2C1_SDA	I2C1_SDA	I2C1_SDA
AA20	I2C8_SCL	GPIO_IO13	I2C8_SCL
AA21	I2C8_SDA	GPIO_IO12	I2C8_SDA
AB13	OTG1_DN	USB1_D_N	USB2.0 OTG1 data -
AC14	OTG1_DP	USB1_D_N	USB2.0 OTG1 data +
AC16	USB_A_EN	IO Expander (I2C2)	Power enable for USB VBUS voltage
AB14	OTG1_ID	USB1_ID	USB2.0 OTG1 ID, high for device, low for host
AC15	OTG1_OC	GPIO_IO10	USB over-current for port A
AB16	USB1_VBUS		USB1_VBUS (5V)
AB23	USB2_DN	USB2_D_N	USB2.0 OTG data -
AC22	USB2_DP	USB2_D_P	USB2.0 OTG data +
AC20	USB_B_EN	IO Expander (I2C2)	Power enable for USB VBUS voltage
AB22	USB2_ID		USB2.0 HOST ID, always low (5V)
AC15	OTG2_OC	ENET2_RXC	USB over-current for port B
AB20	USB2_VBUS	USB2_ID	USB2_VBUS
J21	SD2_NCD	SD2_CD_B	SD card detection
F21	SD2_CLK	SD2_CLK	SDIO clock
E20	SD2_CMD	SD2_CMD	SDIO command / response
G20	SD2_DATA0	SD2_DATA0	SDIO data line
G21	SD2_DATA1	SD2_DATA1	SDIO data line
H20	SD2_DATA2	SD2_DATA2	SDIO data line
H21	SD2_DATA3	SD2_DATA3	SDIO data line

(To be continued...)

Pin	Signal	CPU Pad Name	Description
C20	NVCC_SD2		SDIO A Voltage
D20	SD2_WP		No connection
D21	SD2_NRST		No connection
Y15	CPU_SPI4_SS0	GPIO_IO18	FLASH_CS0
U16	CPU_SPI4_SCLK	GPIO_IO21	FLASH_SCLK
U15	CPU_SPI4_MISO	GPIO_IO19	FLASH_MISO
V15	CPU_SPI4_MOSI	GPIO_IO20	FLASH_MOSI
AB2	PCIE_RXN		No connection
AB1	PCIE_RXP		No connection
AC3	PCIE_TXN		No connection
AC2	PCIE_TXP		No connection
V2	PCIE20_PERST		No connection
W2	PCIE20_CLKREQ		No connection
Y1	PCIE_CLKN		No connection
D17	GPIO_A_0		No connection
E17	GPIO_A_1		No connection
F17	GPIO_A_2		No connection
G17	GPIO_A_3	IO Expander (I2C2)	General purpose I/O Contact A3
H17	GPIO_A_4		No connection
J17	GPIO_A_5	GPIO_IO23	General purpose I/O Contact A5
D19	GPIO_B_0	IO Expander (I2C2)	General purpose I/O Contact B0
E19	GPIO_B_1	IO Expander (I2C2)	General purpose I/O Contact B1
F19	GPIO_B_2	IO Expander (I2C2)	General purpose I/O Contact B2
G19	GPIO_B_3	IO Expander (I2C2)	General purpose I/O Contact B3
H19	GPIO_B_4		No connection
J19	GPIO_B_5		No connection
K19	GPIO_B_6	GPIO_IO24	General purpose I/O Contact B6
L19	GPIO_B_7	IO Expander (I2C2)	General purpose I/O Contact B7
D3	GPIO_C_0	SAI1_TXC	General purpose I/O Contact C0
D4	GPIO_C_1		No connection
E3	GPIO_C_2		No connection
E4	GPIO_C_3	GPIO_IO09	General purpose I/O Contact C3
AF32	GPIO_E_0		No connection

Pin	Signal	CPU Pad Name	Description
AF33	GPIO_E_1		No connection
AG32	GPIO_E_2		No connection
AG33	GPIO_E_3		No connection
AH32	GPIO_E_4		No connection
AH33	GPIO_E_5		No connection
AJ32	GPIO_E_6		No connection
AJ33	GPIO_E_7		No connection
C14	UART3_CTS	GPIO_IO17	UART3_CTS
C13	UART3_RTS	GPIO_IO16	UART3_RTS
A14	UART3_RXD	GPIO_IO15	UART3_RXD
B13	UART3_TXD	GPIO_IO14	UART3_TXD
D14	UART2_RXD	UART2_RXD	UART2_RXD
D13	UART2_TXD	UART2_TXD	UART2_TXD
D22	UART1_RXD	UART1_RXD	UART1_RXD
D23	UART1_TXD	UART1_TXD	UART1_TXD
C22	UART5_RXD	GPIO_IO01	UART5_RXD
C23	UART5_TXD	GPIO_IO00	UART5_TXD
AC17	CAN_A_TX	PDM_CLK	CAN_A_TX
AB17	CAN_A_RX	PDM_BIT_STREAM0	CAN_A_RX
AC19	CAN_B_TX	GPIO_IO25	CAN_B_TX
AB19	CAN_B_RX	GPIO_IO27	CAN_B_RX
M18	ADC_0	ADC_IN1	Analog-Digital Converter 0 (0~1.8V)
N18	ADC_1	ADC_IN2	Analog-Digital Converter 1 (0~1.8V)
F18	PWM_1	SAI1_TXD0	Pulse width modulation 1
G18	PWM_2	SAI1_RXD0	Pulse width modulation 2
E16	ETH_A_RGMII_CRS		No connection
F15	ETH_A_RGMII_COL		No connection
H15	ETH_A_RGMII_TXD0	ENET1_TD0	Transmit data bit 0 (transmitted first) port A
G15	ETH_A_RGMII_TXD1	ENET1_TD1	Transmit data bit 1 port A
H16	ETH_A_RGMII_TXD2	ENET1_TD2	Transmit data bit 2 port A
G16	ETH_A_RGMII_TXD3	ENET1_TD3	Transmit data bit 3 port A
K16	ETH_A_RGMII_TX_EN (_ER)	ENET1_TX_CTL	Transmit enable (Error) port A
J15	ETH_A_RGMII_TX_CLK	ENET1_TXC	Transmit clock port A
K15	ETH_A_RGMII_RXD0	ENET1_RD0	Receive data bit 0 (received first) port A
L15	ETH_A_RGMII_RXD1	ENET1_RD1	Receive data bit 1 port A
N15	ETH_A_RGMII_RXD2	ENET1_RD2	Receive data bit 2 port A
P15	ETH_A_RGMII_RXD3	ENET1_RD3	Receive data bit 3 port A

(To be continued...)

Pin	Signal	CPU Pad Name	Description
L16	ETH_A_RGMII_RX_ER		No connection
M15	ETH_A_RGMII_RX_DV(_ER)	ENET1_RX_CTL	Receive data validation port A
R15	ETH_A_RGMII_RX_CLK	ENET1_RXC	Receive clock port A
N16	ETH_A_SDP		No connection
T15	ETH_MDIO	ENET1_MDIO	Management bus data signal for Ethernet
T16	ETH_MDC	ENET1_MDC	Management bus clock signal for Ethernet
M17	ETH_IOPWR		ETH voltage. Used to provide voltage for all ETH
AM11	LVDS_I2C_CLK	I2C2_SCL	DDC clock line used for flat panel detection and control
AM12	LVDS_I2C_DAT	I2C2_SDA	DDC data line used for flat panel detection and control
AN14	LVDS_VDD_EN		No connection
AN22	LVDS_BL_PWM		No connection
AN23	LVDS_BL_EN		No connection
AN13	LVDS_A_CLK_P	LVDS_CLK_P	LVDS channel A differential pair clock lines
AN12	LVDS_A_CLK_N	LVDS_CLK_N	LVDS channel A differential pair clock lines

Pin	Signal	CPU Pad Name	Description
AP18	LVDS_A_LANE0_P	LVDS_D0_P	LVDS channel A differential pair D0 data lines
AP17	LVDS_A_LANE0_N	LVDS_D0_N	LVDS channel A differential pair D0 data lines
AR16	LVDS_A_LANE1_P	LVDS_D1_P	LVDS channel A differential pair D1 data lines
AR15	LVDS_A_LANE1_N	LVDS_D1_N	LVDS channel A differential pair D1 data lines
AP15	LVDS_A_LANE2_P	LVDS_D2_P	LVDS channel A differential pair D2 data lines
AP14	LVDS_A_LANE2_N	LVDS_D2_N	LVDS channel A differential pair D2 data lines
AP12	LVDS_A_LANE3_P	LVDS_D3_P	LVDS channel A differential pair D3 data lines
AP11	LVDS_A_LANE3_N	LVDS_D3_N	LVDS channel A differential pair D3 data lines
N17	JTAG_TCK(SWCLK)	DAP_TCLK_SWCLK	Test Clock
N19	JTAG_TMS(SWDIO)	DAP_TMS_SWDIO	Test Mode Select
P17	JTAG_TDI	DAP_TDI	Test Data Input
P19	JTAG_RTCK		No connection
R17	JTAG_TDO(SWO)	DAP_TDO_TRACESWO	Test Data Output
R19	JTAG_nTRST		No connection
AC18	DEBUG_EN		No connection
C18	TEST_GENERIC		No connection

* Apart from those specified here, any pins not included in these sheets are not connected.

Ordering Information

Ordering No.	Chipset	Memory	Storage	Description
VOSM93	NXP i.MX 9352	2GB LPDDR4	16GB eMMC	MIPI DSI/LVDS, UART, USB, I ² C, CAN, SPI, RGMII
VT-SBC-VOSM93-EVB	NXP i.MX 9352	2GB LPDDR4	16GB eMMC	VOSM93 + carrier board, MIPI DSI/HDMI, UART, USB, I ² C, CAN, Ethernet

Packing list	
VOSM93 system-on-module	1

Company Profile

Since its establishment in 2002 by two Silicon Valley entrepreneurs, Vantron Technology has been at the forefront of the connected IoT devices and IoT platform solutions. Today, Vantron boasts a global customer base that includes several Fortune 500 companies. Its product lines cover edge intelligent hardware, IoT communication devices, industrial displays and BlueSphere cloud device management platforms.

With over 20 years of experience in R&D of embedded edge intelligent hardware, Vantron has provided users with diverse embedded solutions featuring ARM and X86 architectures. Its offerings range from Linux to Windows, from embedded to desktop level, and from gateway to server. In addition, it provides users with system clipping, driver transplantation and other related services.