

VOSM62L System-on-Module



Product Brief

The VOSM62L system-on-module adopts Texas Instruments AM62L32 Sitara 64-bit industrial SoC and conforms to the solderable LGA specification of the Open Standard Module (OSM) form factor, delivering compact size, optimized power consumption and rich peripheral expansion for cost-focused embedded edge implementation scenarios.









Equipped with a dual-core Arm Cortex-A53 processors clocked up to 1.25GHz, the module is configured with 1GB DDR4 RAM alongside 16GB industrial-grade eMMC flash storage to satisfy local data caching demands.

The module offers rich industrial peripherals routed out through standard OSM pads, consisting of dual Gigabit Ethernet ports, CAN FD buses, GPIOs, multiple UART channels for hardware debugging and on-site serial data collection, as well as USB 2.0 connectivity. Its MIPI DSI interface enables up to 1080P high-definition display. Equipped with TI-native hardware security modules, it supports secure boot, TrustZone isolation and AES/SHA cryptographic acceleration to secure data transmission for payment terminals and smart medical devices.

With support for Linux Yocto operating system, it offers developers with a streamlined development path, backed by long-term software maintenance. This module is ideally suited for a wide range of edge applications, including smart charging piles, building automation controllers, portable medical monitoring terminals and industrial HMI equipment.

Features and benefits

VOSM62L

-  Dual-core Cortex-A53 cost-effective processor
-  Low-power design for high energy efficiency
-  Single display output up to 1080P
-  Rich I/O: USB, UART, I²C, CAN FD, GPIO
-  GbE on module, Wi-Fi & BT on the carrier board
-  Arm TrustZone security technology
-  Linux Yocto operating system support
-  OSM size-L compliant (45mm x 45mm)
-  Extended service life (7+ years)

Application Scenarios



Smart EV Charging



Industrial HMI



Building Automation



Smart Metering



Industrial Automation

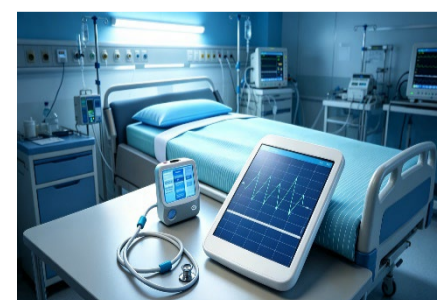

Portable Patient Monitor

VOSM62L System-on-Module Datasheet

Specifications		
System	CPU	TI AM62L32, Dual-core 64-bit Arm® Cortex®-A53 microprocessor, up to 1.25GHz
	Memory	1GB DDR4
	Storage	16GB eMMC 5.1
Communication	Ethernet	GbE MAC (TSN)
Media	Video processing	4-Lane MIPI DSI, 1080P
Power	Input	5V DC input
Software	Operating system	Linux Yocto
Mechanical	Dimensions	45mm x 45mm (OSM Size-L) Packaging: LGA
Miscellaneous	RTC	Integrated RTC
Environmental Condition	Temperature	Operating: -40°C ~ +85°C Storage: -40°C ~ +85°C
	Humidity	5%~95% RH (Non-condensing)

I/O	
Display	1 x 4-Lane MIPI DSI D-PHY, up to 1920 x 1080@60fps
Audio	1 x I ² S, for carrier board codec
Ethernet	2 x RGMII, 10/100/1000Mbps, TSN supported
USB	1 x USB 2.0 OTG
	1 x USB 2.0 Host
SDIO	1 x 4-bit SDIO
ADC	2 x 12-bit ADC
SPI	2 x SPI
CAN	2 x CAN FD, up to 5Mbps
UART	4 x Communication UART
	1 x Debug UART
JTAG	Supported
I ² C	2 x I ² C
GPIO	15 x GPIO
PWM	1 x PWM for MIPI display
	5 x PWM for general use
Key Signal	1 x Reset key

Product Outlines

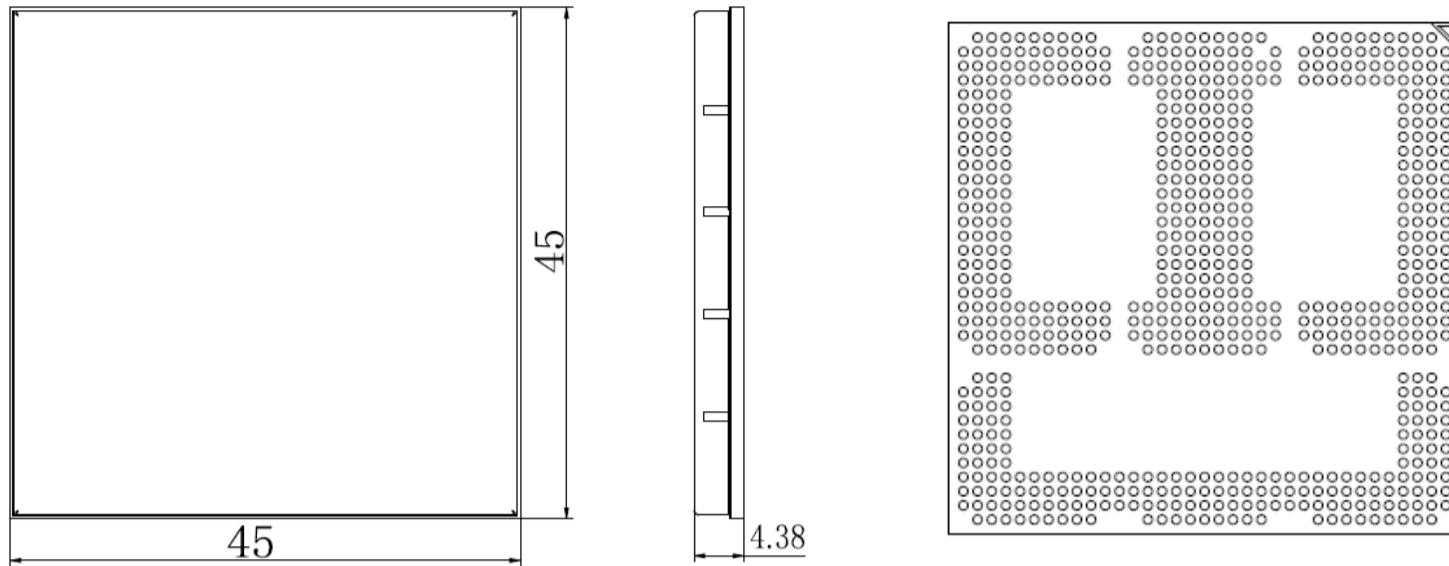

Block Diagram

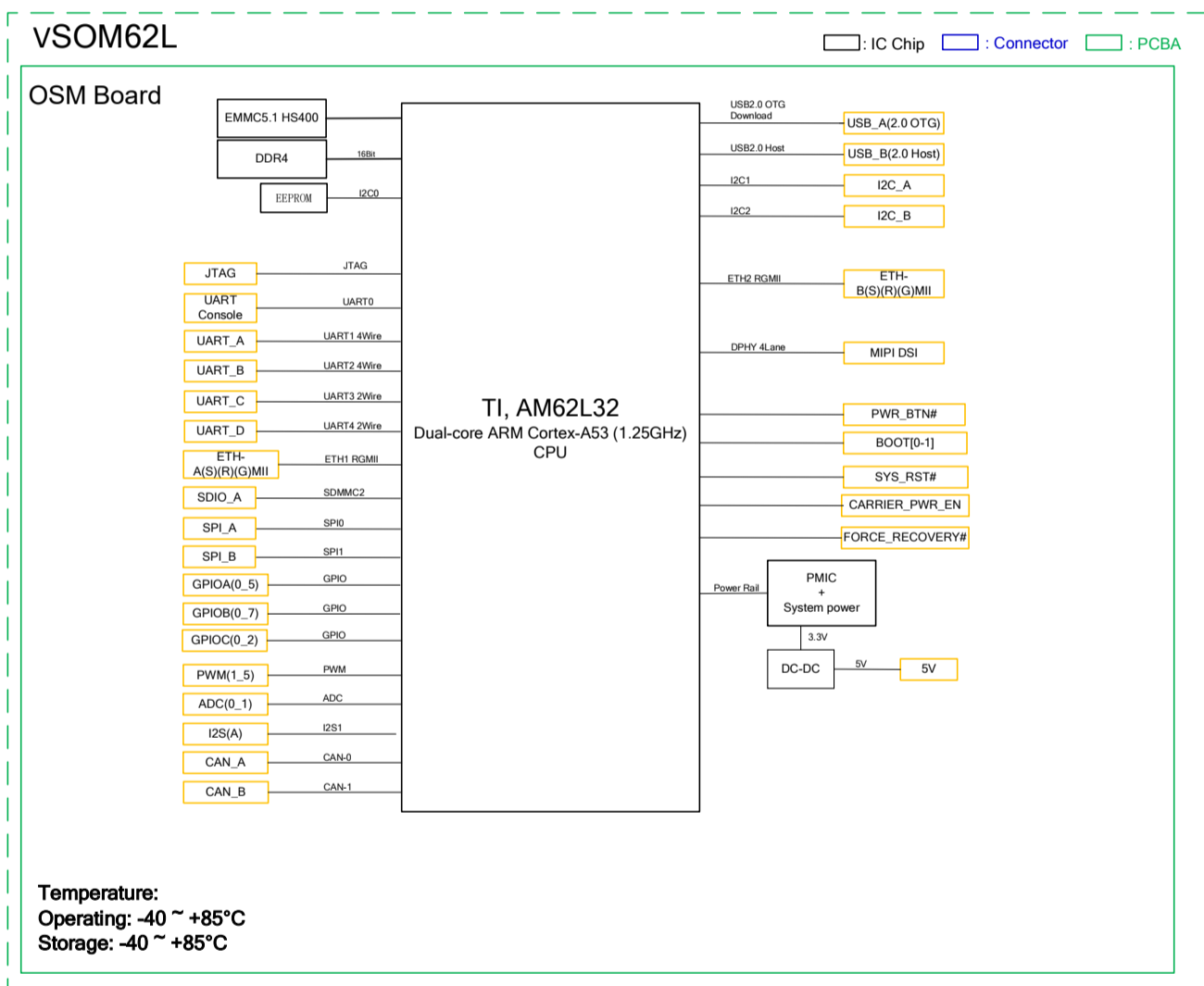

Pinout

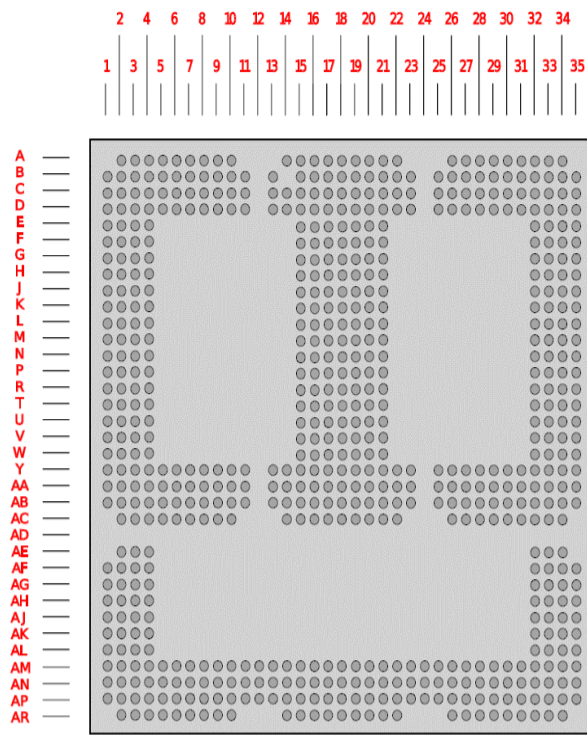

(Bottom View)

In the tables below:

- * **Pin** refers to the pin number defined by OSM as shown in above figure.
- * **Signal** refers to the pin name used by Vantron.
- * **CPU Pad Name** refers to the corresponding designations of the AM62L32 CPU.
- * Certain signals are derived from auxiliary ICs and the corresponding IC names are provided accordingly.
- * Unless otherwise explicitly stated, all I/O signals use a **1.8V level**.

Pin*	Signal*	CPU Pad Name*	Description
U19	BOOTMODE0	GPMCO_AD14	BOOT config[0] BOOT config[1:0]=11=USB DFU BOOT config[1:0]=10=eMMC BOOT config[1:0]=01=USB0
R18	BOOTMODE1	GPMCO_AD15	BOOT config[1] BOOT config[1:0]=11=USB DFU BOOT config[1:0]=10=eMMC BOOT config[1:0]=01=USB0
V17	EXT_EN	GPMCO_BE1N	Carrier power control 1=ON; 0=OFF
T17	NC		No connection
AA9	NC		No connection
W17	RTC_VBAT		RTC power input (3V voltage)
U17	RESETN	RESETZ	RESET KEY 0=active; 1=inactive (PU 10K)
AB18, AA18, M19, Y16, Y20, Y3	NC		No connection
C5, AA33, Y17, Y8, Y9, Y10, Y11	NC		No connection
Y25, Y26, Y27, Y28	VCC_IN_5V		5V power input for the module
AE4, AF4, AG4, AH3	NC		No connection

Pin	Signal	CPU Pad Name	Description
AH4, AJ3, AJ4, AK4 B29, Y19, U18, D18	NC		No connection
E15, E21, F16, F20, J16, J20, L18, M16	GND		Ground
M20, P18, R16, R20, V16, V20, Y18, AA14	GND		Ground
AA17, AA19, AA22, AB15, AB21, A4, A7	GND		Ground
A10, B2, B5, B8, B9, C11, D1, D5, D8, E2	GND		Ground
H2, H4, L2, L4, P2, P4, R1, U2, U4, V1, W3	GND		Ground
Y2, AA1 AA4, AA7 AA8, AA10, AA11, AB3	GND		Ground
AB6, AB9 AC4, AC7, AC10, A26, A29, A32	GND		Ground
B27, B28, B30, B33, C25, C32, C35, D28	GND		Ground
D34, F33, F35, G34, H32, J33, J35, K34	GND		Ground
M35, N34, T34, W34, AA25, AA26, AE2	GND		Ground
AA27, AA28, AA32, AB28, AB31, AB34	GND		Ground
AC27 AC30, AC33, AE34, AF35, AG3	GND		Ground
AH2, AK3, AL2, AH34, AJ35, AL34, AM13	GND		Ground
AM16, AM19, AN3, AM22, AM35	GND		Ground
AN6, AN9, AN11, AP2 AN15, AN18, AP5	GND		Ground
AN21, AN33, AP8, AP13, AP16, AP19	GND		Ground
AP22, AP25, AP28, AP31, AP34, AR14	GND		Ground
AR17, AR20, AR26, AR29, AR32	GND		Ground
F4	LCD_BL_EN	GPMCO_WPN	Backlight enable for MIPI DSI display
E18	BL_PWM	GPMCO_CLK	PWM dimming for MIPI DSI display
F3	LCD_EN	UART0_CTSN	VDD logic enable for MIPI DSI display
AB8	MIPI_DSI1_CKN	DSI_CLOCK_N	MIPI DSI clock -
AB7	MIPI_DSI1_CKP	DSI_CLOCK_P	MIPI DSI clock +
AB11	MIPI_DSI1_DN0	DSI_DATA0_N	MIPI DSI differential data 0 -
AB10	MIPI_DSI1_DPO	DSI_DATA0_P	MIPI DSI differential data 0 +

(To be continued...)

Pin	Signal	CPU Pad Name	Description
AC9	MIPI_DSI1_DN1	DSI_DATA1_N	MIPI DSI differential data 1 -
AC8	MIPI_DSI1_DP1	DSI_DATA1_P	MIPI DSI differential data 1 +
AC6	MIPI_DSI1_DN2	DSI_DATA2_N	MIPI DSI differential data 2 -
AC5	MIPI_DSI1_DP2	DSI_DATA2_P	MIPI DSI differential data 2 +
AB5	MIPI_DSI1_DN3	DSI_DATA3_N	MIPI DSI differential data 3 -
AB4	MIPI_DSI1_DP3	DSI_DATA3_P	MIPI DSI differential data 3 +
AA3	LCD_ID	GPMCO_CSN1	ID of MIPI DSI display
M18	ADC0_AIN0	ADC_0	ADC input (12-bit)
N18	ADC0_AIN1	ADC_1	ADC input (12-bit)
AC18	NC		No connection
R19	JTAG_TRSTN	TRSTN	JTAG test reset, active low
P19	NC		No connection
N17	JTAG_TCK	TCK	JTAG test clock
P17	JTAG_TDI	TDI	JTAG test data in
R17	JTAG_TDO	TDO	JTAG test data out
N19	JTAG_TMS	TMS	JTAG test mode select
F18	PWM_1	EXT_REFCLK1	Pulse width modulation 1
G18	PWM_2	GPMCO_WEN	Pulse width modulation 2
H18	PWM_3	GPMCO_AD0	Pulse width modulation 3
J18	PWM_4	GPMCO_AD1	Pulse width modulation 4
K18	PWM_5	GPMCO_AD9	Pulse width modulation 5
AB17	CAN0_TX	MCAN0_TX	CAN0 transmit data
AC17	CAN0_RX	MCAN0_RX	CAN0 receive data
AB19	CAN1_TX	GPMCO_DIR	CAN1 transmit data
AC19	CAN1_RX	GPMCO_WAIT1	CAN1 receive data
C14	UART1_CTSn	MCASPO_AXR3	UART clear to send
C13	UART1_RTSn	MCASPO_AXR2	UART request to send
A14	UART1_RXD	MCASPO_AFSR	UART receive data
B13	UART1_TXD	MCASPO_ACLKR	UART transmit data
D16	UART2_CTSn	MMC1_DAT0	UART B clear to send
D15	UART2_RTSn	MMC1_DAT1	UART B request to send
D14	UART2_RXD	MMC1_DAT3	UART B receive data
D13	UART2_TXD	MMC1_DAT2	UART B transmit data
A22	UART3_RXD	MMC1_CLK	UART C receive data
B23	UART3_TXD	MMC1_CMD	UART C transmit data
D22	UART0_RXD	UART0_RXD	Debug UART receive data
D23	UART0_TXD	UART0_TXD	Debug UART transmit data
C22	UART4_RXD	GPMCO_CSN2	UART D receive data
C23	UART4_TXD	GPMCO_CSN3	UART D transmit data
V21	I2S0_RXD0	MCASPO_AXR0	I2S A receive data
W21	I2S0_TXD0	MCASPO_AXR1	I2S A transmit data

Pin	Signal	CPU Pad Name	Description
V19, W19	NC		No connection
W20	I2S0_BCLK	MCASPO_ACLKX	MI2S0 serial clock
W18	I2S0_LCLK	MCASPO_AFSX	MI2S0 word select
AA15	I2C_A_SCL	I2C1_SCL	I2C A serial clock (PU 4.7k)
AA16	I2C_A_SDA	I2C1_SDA	I2C A serial data (PU 4.7k)
AA20	I2C_B_SCL	I2C2_SCL	I2C B serial clock (PU 4.7k)
AA21	I2C_B_SDA	I2C2_SDA	I2C B serial data (PU 4.7k)
AC15, AC21, AB22	NC		No connection
AB13	USB0_DM	USB0_DM	USB A high-speed data -
AC14	USB0_DP	USB0_DP	USB A high-speed data +
AB14	USB0_ID	SPIO_CS1	USB A OTG ID
AB16	USB0_VBUS	USB0_VBUS	USB-A VBUS (5V)
AC16	USB0_DRVVBUS	USB0_DRVVBUS	USB-A enable
AB23	USB1_DM	USB1_DM	USB B high-speed data -
AC22	USB1_DP	USB1_DP	USB B high-speed data +
AC20	USB1_DRVVBUS	USB1_DRVVBUS	USB-B enable
AB20	USB1_VBUS	USB1_VBUS	USB-B VBUS (5V)
J21	MMC2_CD	MMC2_SDCD	SDMMC detection (PU 10K)
F21	MMC2_CLK	MMC2_CLK	SDMMC 2 clock
E20	MMC2_CMD	MMC2_CMD	SDMMC 2 command (PU 10K)
G20	MMC2_D0	MMC2_DAT0	SDMMC 2 data bit 0
G21	MMC2_D1	MMC2_DAT1	SDMMC 2 data bit 1
H20	MMC2_D2	MMC2_DAT2	SDMMC 2 data bit 2
H21	MMC2_D3	MMC2_DAT3	SDMMC 2 data bit 3
C20	VCC_SD		SDMMC 2 VDDIO (1.8V)
D21	MMC2_PWR_EN	MMC2_SDWP	Voltage regulator (1.8V)
D17	GPIO_A_0	UART0_RTsn	GPIO/defined on carrier
E17	GPIO_A_1	OSPIO_CLK	GPIO/defined on carrier
F17	GPIO_A_2	OSPIO_D0	GPIO/defined on carrier
G17	GPIO_A_3	OSPIO_D1	GPIO/defined on carrier
H17	GPIO_A_4	OSPIO_D2	GPIO/defined on carrier
J17	GPIO_A_5	OSPIO_D3	GPIO/defined on carrier
D19	GPIO_B_0	OSPIO_D4	GPIO/defined on carrier
E19	GPIO_B_1	OSPIO_D5	GPIO/defined on carrier
H19	GPIO_B_4	OSPIO_CSN0	GPIO/defined on carrier
J19	GPIO_B_5	OSPIO_CSN1	GPIO/defined on carrier
K19	GPIO_B_6	OSPIO_CSN2	GPIO/defined on carrier
L19	GPIO_B_7	OSPIO_CSN3	GPIO/defined on carrier
D3	GPIO_C_0	OSPIO_DQS	GPIO/defined on carrier
D4	GPIO_C_1	OSPIO_LBCLKO	GPIO/defined on carrier
E3	GPIO_C_2	GPMCO_OEN_REN	GPIO/defined on carrier

(To be continued...)

Pin	Signal	CPU Pad Name	Description
Y15	SPI0_CS0	SPI0_CS0	SPI_A chip select, active low
U16	SPI0_CLK	SPI0_CLK	SPI_A serial clock
U15	SPI0_DI	SPI0_D0	SPI_A serial data in
V15	SPI0_DO	SPI0_D1	SPI_A serial data out
AA23	SPI1_CS0	GPMCO_AD4	SPI_B chip select, active low
Y21	SPI1_CLK	GPMCO_AD5	SPI_B serial clock
Y22	SPI1_DI	GPMCO_AD2	SPI_B serial data in
Y23	SPI1_DO	GPMCO_AD3	SPI_B serial data out
C30, D29, C29, D30, F15, E16	NC		No connection
L16, N16, E1, D2	NC		No connection
K2, C6, C7, M2	NC		No connection
H15	ENET_A_RGMII_TXD0	RGMII1_TD0	RGMII1 transmit data 0
G15	ENET_A_RGMII_TXD1	RGMII1_TD1	RGMII1 transmit data 1
H16	ENET_A_RGMII_TXD2	RGMII1_TD2	RGMII1 transmit data 2
G16	ENET_A_RGMII_TXD3	RGMII1_TD3	RGMII1 transmit data 3
K16	ENET_A_RGMII_TXCTL	RGMII1_TX_CTL	RGMII1 transmit control
J15	ENET_A_RGMII_TXCLK	RGMII1_TXC	RGMII1 transmit clock
K15	ENET_A_RGMII_RXD0	RGMII1_RD0	RGMII1 receive data 0
L15	ENET_A_RGMII_RXD1	RGMII1_RD1	RGMII1 receive data 1

Pin	Signal	CPU Pad Name	Description
N15	ENET_A_RGMII_RXD2	RGMII1_RD2	RGMII1 receive data 2
P15	ENET_A_RGMII_RXD3	RGMII1_RD3	RGMII1 receive data 3
M15	ENET_A_RGMII_RXCTL	RGMII1_RX_CTL	RGMII1 receive control
R15	ENET_A_RGMII_RXCLK	RGMII1_RXC	RGMII1 receive clock
T15	ENET_MDIO	MDIO0_MDIO	MDIO data
T16	ENET_MDC	MDIO0_MDC	MDIO clock
M17	VDD_1V8		ETH IO Power (1.8V)
G1	ENET_B_RGMII_TXD0	RGMII2_TD0	RGMII2 transmit data 0
F1	ENET_B_RGMII_TXD1	RGMII2_TD1	RGMII2 transmit data 1
G2	ENET_B_RGMII_TXD2	RGMII2_TD2	RGMII2 transmit data 2
F2	ENET_B_RGMII_TXD3	RGMII2_TD3	RGMII2 transmit data 3
J2	ENET_B_RGMII_TXCTL	RGMII2_TX_CTL	RGMII2 transmit control
H1	ENET_B_RGMII_TXCLK	RGMII2_TXC	RGMII2 transmit clock
J1	ENET_B_RGMII_RXD0	RGMII2_RD0	RGMII2 receive data 0
K1	ENET_B_RGMII_RXD1	RGMII2_RD1	RGMII2 receive data 1
M1	ENET_B_RGMII_RXD2	RGMII2_RD2	RGMII2 receive data 2
N1	ENET_B_RGMII_RXD3	RGMII2_RD3	RGMII2 receive data 3
L1	ENET_B_RGMII_RXCTL	RGMII2_RX_CTL	RGMII2 receive control
P1	ENET_B_RGMII_RXCLK	RGMII2_RXC	RGMII2 receive clock

* Apart from those specified here, any pins not included in these sheets are not used.

Ordering Information

Ordering No.	Memory	Storage	Connectivity	Description
VOSM62L	1GB DDR4	16GB eMMC	GbE	MIPI DSI, SPI, CAN, UART, USB, I ² C, I ² S, GPIO
VT-SBC-VOSM62L-EVB	1GB DDR4	16GB eMMC	GbE, Wi-Fi, Bluetooth	VOSM62L + Carrier board, MIPI DSI, UART, CAN, Audio, USB, GPIO

Packing List	
VOSM62L system-on-module	1

Company Profile

Since its establishment in 2002 by two Silicon Valley entrepreneurs, Vantron Technology has been at the forefront of the connected IoT devices and IoT platform solutions. Today, Vantron boasts a global customer base that includes many Fortune Global 500 companies. Its product lines cover edge intelligent hardware, IoT communication devices, industrial displays and BlueSphere cloud platforms.

With over 20 years of experience in R&D of embedded edge intelligent hardware, Vantron has provided users with diverse embedded solutions featuring ARM and X86 architectures. Its offerings range from Linux to Windows, from embedded to desktop level, and from gateway to server. In addition, it provides users with system trimming, driver transplantation and more to cater to the unique needs of its users.