

M100 10" General-purpose Industrial Tablet



Product Brief

Vantron M100 high-performance general-purpose industrial tablet was designed for industrial applications, especially in retail businesses, multi-media education, transportation, laboratories, and libraries. The industrial tablet is powered by Intel® Atom multi-core processor with a 10.1-inch capacitive touchscreen to offer excellent human-machine interactive experience. It has up to 4GB memory and 64GB storage to store massive data and finish data processing within very short time.

Aside from rich interfaces for different peripherals, the device provides Ethernet, Wi-Fi, Bluetooth and 4G communication options to adapt to diversified networking requirements of different industrial scenarios. Moreover, the device features high reliability, and users have the option of installing a TPM module for intensified security.

Exterior and Features



M100

- 2GB Memory and 32GB Storage
- 5MP cameras
- 7350mAh Battery
- 10.1" IPS TFT LCD, Resolution: 1280 x 800
- Micro HDMI for extended display
- Ethernet, Optional Wi-Fi/ BT/4G/NB-IoT
- RTC supported

M100 10" General-purpose Industrial Tablet Datasheet

M100		
System	CPU	Intel® Atom Apollo Lake N3350, Dual-core processor, 2.4GHz / N3450, Quad-core processor, 2.2GHz
	Memory	2GB LPDDR4 (Optional: 4GB)
	Storage	32GB eMMC (Optional: 64GB) 1 x Micro SD / micro SDHC / micro SDXC
Communication	Ethernet	1 x RJ45, 1000Mbps
	Wi-Fi & Bluetooth	Optional (expansion by M.2 SSD/Mini PCIe)
	4G/NB-IoT	Optional (expansion by Mini PCIe), with a SIM slot
Media	Display	10.1" IPS TFT LCD, Resolution: 1280 x 800; 350 nits (typical) 1 x Micro HDMI: up to 3480 x 2160 @30Hz
	TP	10-point capacitive touchscreen
	Camera	Front and rear cameras: 5MP
	Audio	1 x 3.5mm combo audio jack 1 x Speaker
I/O	USB	1 x USB2.0 Type-A 1 x USB Type-C
	RTC	Supported
Expansion	Security	1 x TPM module (Optional)
	M.2	1 x M.2 SSD, optional for Wi-Fi & Bluetooth
	Mini PCIe	1 x Mini PCIe, optional for Wi-Fi & Bluetooth or 4G/NB-IoT
Sensor	Light sensor	1 x Light sensor
System Control	Button	1 x Power on/off
		1 x Volume +/-
Software	OS	Windows 10 or Linux
System	SDK	Available
	Power in	12V DC
	Battery	Single-cell Li-ion battery: 7.2V, 7350mAh
Mechanical	Dimensions	262mm x 184mm x 16mm
	Weight	1.1kg
Environmental Condition	Temperature	Operating: 0°C~+45°C
		Storage: -10°C~+55°C
	Humidity	Operating: 20%-80% RH
Storage: 10%-90% RH (Non-condensing)		
	Certification	CE

Product Outlines

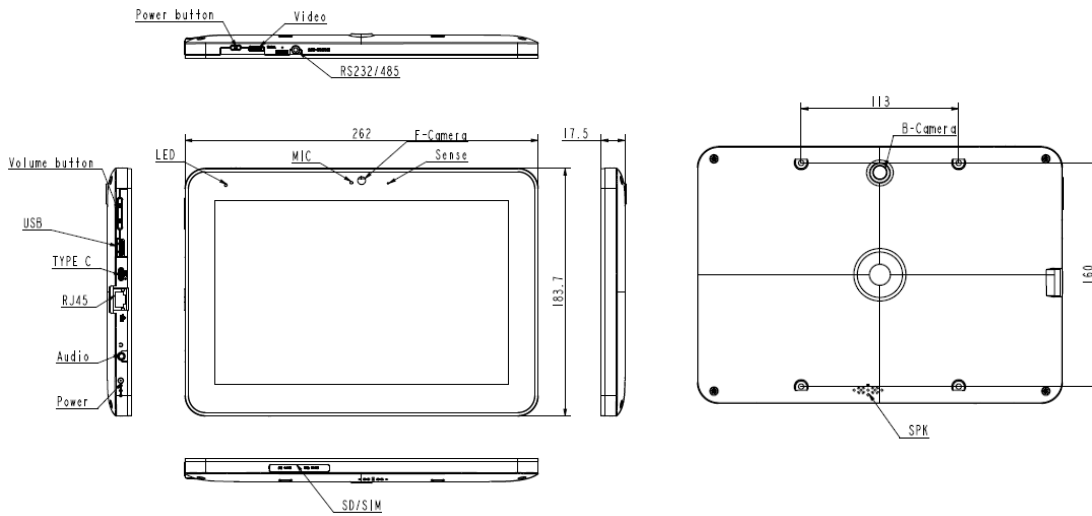

Ordering Information

Ordering No.	Memory	Storage	Processor
M100-L33	2GB	32GB	Apollo Lake N3350
M100-L34	2GB	32GB	Apollo Lake N3450
M100-H33	4GB	64GB	Apollo Lake N3350
M100-H34	4GB	64GB	Apollo Lake N3450

Packing list	
M100 Industrial tablet	1
5V/2A Power adapter	1
USB cable	1

Since its establishment in 2002 by two Silicon Valley entrepreneurs, Vantron Technology has been at the forefront of the connected IoT devices and IoT platform solutions. Today, Vantron boasts a global customer base that includes several Fortune 500 companies. Its product lines cover edge intelligent hardware, IoT communication devices, industrial displays and BlueSphere cloud device management platform.

Vantron's intelligent display systems are comprised of industrial tablets, touchscreen monitors and all-in-one panel PCs that deliver enhanced device performance and exceptional human-machine interactive experience. The industrial tablets are powered by industry-leading brands such as Rockchip, NXP, MediaTek, and Intel. The touchscreen monitors offer flexible installation options to cater to various application scenarios. The all-in-one panel PCs offer an overall solution that integrates the touchscreen monitor, display, processor, and operating system. Moreover, the displays are built to excel in harsh environments thanks to advanced features like waterproofing, dustproofing, and shatter resistance.